

Energy Efficiency Best Practice Guide

Steam Systems, Hot Water Systems and Process Heating Systems



Contents

1. Introduction	5
2. Summary of considerations to promote energy efficiency in process heat applications	6
3. The business benefits of steam system, hot water system and process heating system efficiency	7
4. What is your opportunity?	8
5. Steam systems	9
6. Hot water systems	26
7. Process heating systems	36
8. Selecting a service provider	42

Appendices

Appendix A: Steam system overview	43
Appendix B: Hot water system overview	48
Appendix C: Process heating system overview	50
Appendix D: Fuel properties	53
Appendix E: Glossary	54
Appendix F: Further reading	56

Figures

Figure 1: Typical Lifestyle cost of a steam system	7
Figure 2: Typical heat and energy losses from a boiler	10
Figure 3: Flash steam recover vessel	15
Figure 4: The combustion zone of a typical simple industrial solid fuel boiler	27
Figure 5: Simple industrial boiler illustrating air bypassing the grate	27
Figure 6: Large number of combustor starts	29
Figure 7: Small number of combustor starts	29
Figure 8: Typical basic steam circuit	43
Figure 9: Steam accumulator (side and end views)	45
Figure 10: Typical flow path through fire-tube shell boiler	46
Figure 11: Modern package boiler	46
Figure 12: Water-tube boiler	47
Figure 13: Basic components in a commercial hot water boiler system	48
Figure 14: Key components of a process heating system	50

Tables

Table 1: Some quantified energy saving opportunities for boilers	11
Table 2: Steam leakage rates	13
Table 3: Heat loss from uninsulated piping	15
Table 4: Process heating classification	51

1. Introduction

The nature of heat plant in New Zealand is changing. Large steam boilers were common in industry and commercial applications, but are becoming less so as they are replaced with more efficient hot water boilers and smaller steam generators located close to the end-users. This shift is an opportunity to improve the performance of New Zealand's heat plant – by ensuring they are operated, maintained and installed in the most effective manner.

This document is a guide to improving energy efficiency in boilers, steam systems, hot water systems and process heating to achieve best practice - and help you realise benefits for your business.

Topics covered by this guide include:

- What are the basic components of industrial steam, hot water and process heating systems?
- How can I tell if the system is functioning efficiently?
- What are the areas where systems can be improved to operate more efficiently?
- What energy source should I use?

The guide has been developed to lead decision makers, operators and maintenance providers through a process to help them identify the actions and opportunities to improve the operation and performance of equipment, reduce operating costs and improve environmental outcomes. It is not intended to be a thorough technical guide. References for more detailed technical information are provided.

It is also recommended that the reader is familiar with the requirements for safe design and operation of boilers and associated equipment. The relevant codes of practice are the:

- approved code of practice for the design, safe operation, maintenance and servicing of boilers
- approved code of practice for pressure equipment.

Both of these documents can be found on the Department of Labour – Health and Safety website (www.osh.govt.nz).

2. Summary of considerations to promote energy efficiency in process heat applications

Whole system

- Is the heat transfer fluid appropriate to the end-use and demand?
 - Are the temperatures and pressures used appropriate for the end-use?
 - Are there opportunities to spread the load?
 - Are there remote end-users that could be better serviced by a small dedicated heat source?
 - What opportunities are there to use waste heat from other processes?
 - What opportunities exist for heat storage to flatten the load profile?
 - Use efficient end-user equipment.
-

Boilers

- Check and monitor the excess air.
 - Check the distribution of the fuel on the bed in solid fuel combustion systems.
 - Check the flame patterns in a liquid or gaseous fuel combustion system.
 - What opportunities exist to change the fuel type to one with more efficient combustion or lower carbon intensity?
 - Is there an opportunity to fit an economiser?
 - What combustion air pre-heat could be used?
 - Check for insulation damage and air leaks.
 - Ensure the heat transfer surfaces are clean, or can be cleaned easily and often.
 - Review boiler set points to minimise short cycling.
 - Modify boiler sequencing to ensure the most appropriate boiler is matched to the demand.
-

Distribution system

- Ensure distribution system is rationalised and all dead legs removed.
 - Ensure distribution system pipe sizes are appropriate for the demand.
 - Remove throttling valves and make use of VSDs on all pumping systems.
 - Repair leaks.
 - Insulate the distribution system.
 - Re-route any hot piping that may be passing through chilled or air conditioned spaces.
-

Process heating systems

- What opportunities exist for pre-heating combustion air?
- What opportunities exist for heat recovery?
- Check the air-fuel ratio.
- Check the heating patterns to avoid hot and cold spots.
- Check condition of heating equipment and ensure its optimal operation.
- Insulate the process.
- Minimise conductive losses through support structures.

3. The business benefits of steam system, hot water system and process heating system efficiency

Steam, hot water and process heating are all essential resources of many industries. They often provide convenient, reliable and cost-effective energy with which to undertake the processes that are fundamental to your business. As such an indispensable tool, there are great benefits to be gained from running these systems at their optimum efficiency, providing the best performance, safety and energy efficiency possible.

Figure 1 illustrates that the cost of energy consumption in a steam system is almost the entirety of the system's cost (based on data for boilers with a high rate of capacity utilisation over a 20-year life). It makes good business sense, therefore, to run an energy-efficient system.

Figure 1: Typical Lifestyle cost of a steam system

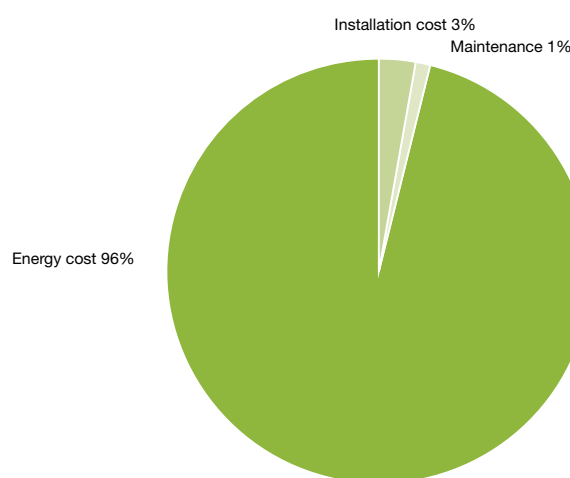

Not only is energy cost a large part of the overall cost of owning a process heating system, but process heating in New Zealand consumed approximately 112TJ in 2007 compared to the 158TJ consumed by the industrial and primary production sectors (excluding transport, aluminium and Iron reduction). Of this 90TJ were consumed by boilers.¹⁴ This is a quantity of energy that rivals the total consumption of the commercial transport and storage sectors. These statistics show that running an energy-efficient steam, hot water or process heating system will greatly improve your business's energy consumption, bringing benefits both for your bottom line and the environment.

Under the Emissions Trading Scheme and the potential for future carbon charges, cost savings can be achieved through using carbon neutral fuels either as a complete substitution in a suitable fossil fuel fired solid fuel boiler, or introduced as a mix with the fossil fuels or through replacement of the boiler with a dedicated biomass boiler. See the EECA Business website (www.eecabusiness.govt.nz) for toolkits and examples.

Additional benefits are possible with reduced waste streams where on site waste can be used as the fuel source.

4. What is your opportunity?

Delivering the best outcomes for your business requires a whole-systems approach to the design, installation, operation and maintenance of your steam, hot water or process heating system.

Defining the limitations of your current system is the key to finding the best solution to achieving energy efficiency for your business:

- How do I make my existing system more efficient?
- Do I need some new system components?
- How do I expand my existing system?
- What do I need to know to install a new system?
- What are the opportunities for generating process heat another way?

This guide offers step-by-step solutions to help you identify the opportunities to implement best practice to achieve energy efficiency of your steam system, hot water system or process heating system.

Solution 1: Improve the efficiency of your existing system

Is your steam, hot water or process heating system fulfilling needs but could run more efficiently? Perhaps your system is struggling to meet the plant needs at particular times of the day or week. This process may only involve a small investment, but can provide significant savings and costs.

Solution 2: Design a new system

If you are planning a new steam, hot water or process heating system, this process outlines the steps required to ensure you achieve excellent design and to help you understand where to spend your valuable capital.

If your requirements have changed (for example, if there have been significant upgrades to the process plant or equipment), you may need to install more efficient equipment or expand your current system. This will involve elements of both solutions. Firstly, ensure your existing system is running efficiently (Solution 1) and secondly, design the new components of the expanded system (Solution 2). Following this process will ensure that you are not wasting money purchasing more than you actually need. It also seeks to help you recognise the range of opportunities for smarter use of the energy that may be present on your site.

5. Steam systems

5.1 Solution 1: Improve the efficiency of your existing system

There are many practical and proven methods for improving the efficiency of your existing steam system, and it is important to choose the ones appropriate to your circumstances.

A suggested process to follow for improving the efficiency of your steam system is summarised as follows:

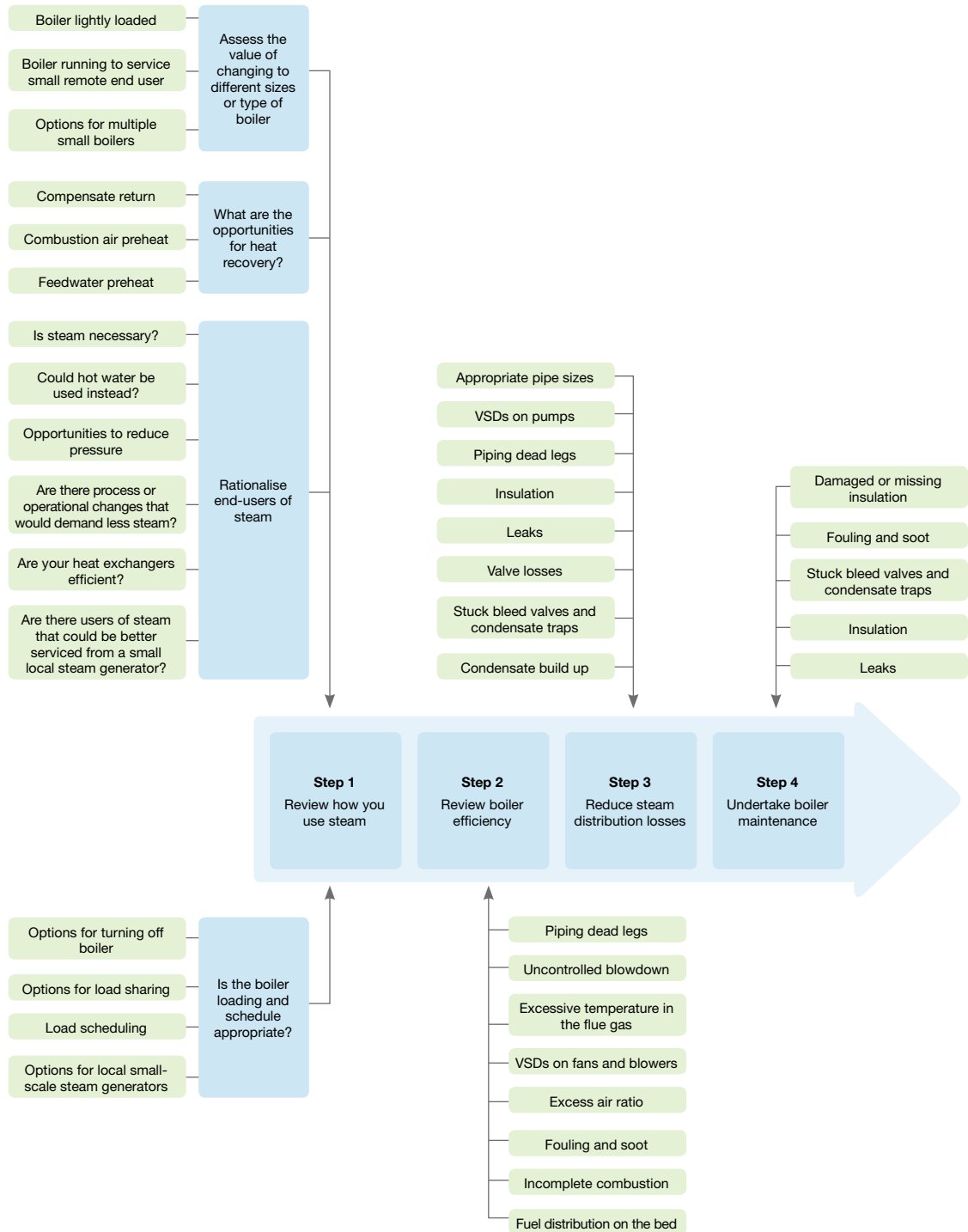

5.1.1 Step 1: Review how you use steam

The first step to improving your steam system is to review how you use steam and why you need it. Ask yourself the following questions for each of your processes that use steam:

- What pressure, temperature and flow does it require?
- How do these requirements match with your steam supply conditions?
- Could you lower the temperature of your steam supply?
- Could you use another source of heat, such as waste heat from another process or piece of equipment?
- Can you alter the times at which steam is needed in order to create a more constant load at the boiler?
- Could you use steam storage and therefore a smaller boiler?
- Is steam being used for unsafe or inappropriate uses, such as heating water directly? (The energy and cost spent in treating the steam is then lost as compared to returning the condensate.)
- Is the steam use very small and the distance from the boiler large? Could a local small steam generator be used instead?
- Do you need steam at all? Can an equivalent service be provided by a hot water or pumped heat transfer fluid system?

Your steam system may not be meeting your needs efficiently, in which case a steam service provider can be consulted to suggest how your system may be improved. Request that they take a systems approach and keep your business needs in mind.

5.1.2 Step 2: Review boiler efficiency

Heat and energy losses in a typical packaged boiler can be illustrated by the following diagram, along with typical-energy saving initiatives.

Figure 2: Typical heat and energy losses from a boiler

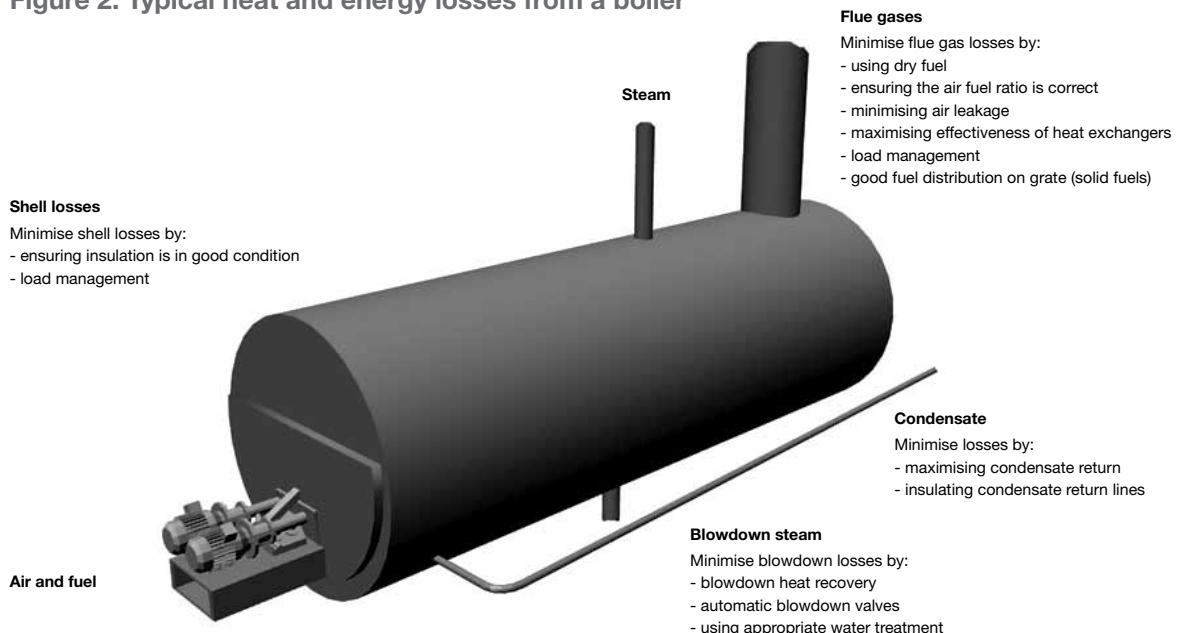

Opportunities for efficiency improvement are therefore related to reducing losses in these areas. Table 1 illustrates some boiler energy efficiency improvements and the expected energy saving potential.

Table 1: Some quantified energy saving opportunities for boilers^{4,12}

Technique/Method	Problem
Improved operation and maintenance of boilers	Up to 5%
Improved water treatment and boiler water conditioning	Up to 2%
Total dissolved solids (TDS) control and boiler blowdown	Up to 2%
Blowdown heat recovery	Up to 3%
Boiler and burner management systems, digital combustion controls and oxygen trim	Up to 5%
Variable speed drives (VSDs) for combustion air fans	
Flue gas shut-off dampers	Up to 1%
Economisers	Up to 5%
Combustion air preheating	Up to 2%

Note: Because potential boiler operation energy savings are split into three largely independent activities – combustion, water treatment and the steam/condensate system – Individual energy savings measures are usually cumulative, although some combinations of energy savings action will sometimes reduce the potential savings of another action.

Key steps to improving boiler efficiency⁵

1. Improve operation and maintenance

The first step to running a more energy-efficient boiler is to measure its current efficiency as a baseline and determine if its efficiency is within a good operating range as compared to the boiler specifications. With some simple measurements of steam temperature and pressure, feedwater temperature and pressure, steam flow rate and fuel consumption rate you can accurately determine boiler efficiency.

Faulty insulation or refractory damage can be detected through the presence of hotspots on the outer skin of the boiler. These may be able to be detected visually through paint discolouration or by feel. If left unresolved, they can lead to accelerated deterioration of the boiler and the potential release of toxic flue gases into the boiler room space.

2. Investigate opportunities for feedwater quality improvement

Improving the feedwater quality will lead to a decreased blowdown rate and other benefits throughout the steam distribution system. However, any opportunity that will require higher energy or cost in treating the water should be carefully evaluated against boiler blowdown energy losses to ensure the lowest energy and lowest cost solution is found.

3. Determine boiler blowdown rate (% of feedwater flow, kg/h)

Boiler blowdown is an important part of maintaining boiler performance and the need for it is determined by the total dissolved solids (TDS) in the water. The allowable level of TDS for a boiler is typically specified by the manufacturers and varies depending on the type of boiler. Automatic blowdown valves that can detect the TDS are a recommended way of controlling the blowdown to ensure the TDS levels remain within the boiler's tolerance as well as ensuring blowdown events and their subsequent loss of heat are minimised. Automatic blowdown valves are mandatory on all unattended boilers. Automatic control of the blowdown process will also reduce water treatment costs by reducing the loss of treated water from the system.

The style of boiler will have an effect on its tolerance for TDS in the water. A fire-tube boiler typically has a recommended TDS in the 1800ppm to 2200ppm range. A high-performance wire-tube boiler has a much lower TDS tolerance due to the higher rate of water circulation and steam drum turbulence in that type of boiler.

4. Investigate blowdown heat recovery opportunities

The blowdown water contains significant energy that can be recovered. Two main methods are used. Flash steam is created when blowdown occurs and if the blowdown steam is directed to a flash steam vessel, the flash steam can be recovered for low-pressure steam applications or sent to the de-aerator. Blowdown water from either the blowdown steam or the liquid drain of the flash steam vessel could also be used to preheat feedwater (or other water) using a heat exchanger. Since the water has a high concentration of dissolved solids, the heat exchanger should be resistant to fouling and able to be easily cleaned.

5. Boiler combustion management

Minimising excess air in combustion is one of the key energy efficiency initiatives for boilers. The more hot oxygen, nitrogen and water vapour that escapes from the flue, the more energy you lose. By analysing the oxygen concentration of the flue gas (%), you can easily determine if too much excess intake air is being used or if air leakage is occurring through the fuel bed. This can then be controlled through regular checking and adjustment, or through an automatic oxygen trim control.

The flue gas exhaust temperature is also a good indicator of the efficiency of your boiler. By measuring the flue temperature daily and seeing how it changes as compared to steam load, ambient temperature and the oxygen content, you can quickly pick up any efficiency problems. Keeping the flue gas temperature as low as possible is important in maintaining energy efficiency.

The concentration of combustible material in the flue gas is not only an efficiency matter but also one of safety. High concentrations are dangerous and may show that there is insufficient combustion intake air or that the air flows are so high that combusting particles are carried out of the combustion zone before they are fully burned. Combine this measurement with that of the oxygen concentration to determine if the combustion intake air amount should be changed. Problems may also be due to insufficient time that the fuel is in the combustion zone or insufficient mixing of oxygen and the fuel, or poor distribution of solid fuels on the combustor grate.

Unburned carbon loss is generally a problem in coal-fired and other solid fuel boilers. By analysing the carbon concentration in the ash it is possible to see if your unburnt carbon levels are within a normal range. High levels are a sign of inefficient combustion, which is increasing your fuel costs. Changes may need to be made to your stoker or grate arrangements.

6. Economiser

Consider the application of an economiser. An economiser is a heat exchanger that captures heat from the hot flue gases and transfers it to the boiler feedwater. While the gases in the flue are a lower temperature than in the boiler combustion chamber, the relatively low temperature of the feedwater means that heat transfer from the hot flue gases to the feedwater is high. The heat gained by the feedwater will raise its temperature, resulting in less heat at a high temperature, and hence less fuel, will be required to convert the water to steam – and heat it to the operating temperature.

5.1.3 Step 3: Reduce steam distribution losses

While the boiler itself is an important area for improvement, the rest of the steam system is just as important for improving energy efficiency and performance. Supply of steam and return of the condensate over long distances is an expensive activity both in terms of operational costs and capital costs. Where possible, it may be advantageous to transfer the heat from the steam to another heat transfer medium with less demanding operating requirements within the boiler house. However, if steam is an essential part of the process then the following steps can help reduce your energy losses in the distribution system.

Key steps to reducing steam distribution system losses

1. Find and repair steam leaks

Steam leaks are a big cause of energy loss from steam systems. Leaks generally occur in pipe sections or connections and steam traps that drain condensate. Table 2 shows the cost of steam leaks at various pressures and hole sizes.

Table 2: Steam leakage rates⁵

Hole diameter (mm)	Leak rate (kg/hour) at steam temperature 260°C steam pressure (kPa above atmospheric)						
	345	689	1034	1379	1724	2068	2413
3.2	12	21	30	39	48	60	67
6.4	46	82	118	153	191	239	268
9.5	103	183	265	347	430	538	604
12.7	183	326	470	606	764	956	1073
19.1	411	733	1058	1387	1719	2151	2413
25.4	731	1303	1881	2465	3056	3824	4290
31.8	1143	2036	2938	3851	4776	5975	6703
38.1	1645	2931	4231	5546	6877	8604	9653

Leaks can be detected by sight and hearing, while ultrasonic leak detection can be used for smaller leaks. The most effective repairs on steam pipe leaks can be made when the steam system is not operating, as the maintenance crew gets extensive and safe access to the piping. If the leak is a safety hazard or system downtime will not occur for some time, then repairs can be made while the steam system is online. However, only trained technicians should do the work and the repair may not be as effective.

2. Implement a steam trap management programme

Steam traps are devices that are essentially automatic drain valves. They ensure that all of the steam in the process is converted to condensate before leaving the system while, at the same time, preventing any accumulation of condensate in the system which may result in a potentially dangerous phenomenon known as water hammer. By ensuring that all of the steam is condensed in your process, latent heat recovery is maximised. It can be shown that in a typical packaged boiler operating at 10bar pressure, over 80% of the energy stored in the steam is in the form of latent heat. Failure to recover that latent heat (for example, a faulty steam trap), results in major energy loss and on many steam systems, steam trap maintenance represents an opportunity for significant cost saving.

The loss of steam from a properly functioning steam trap is negligible.

Normal wear and tear, debris in the steam system or improper application of steam traps can lead to trap failure. If the trap fails while open, steam will be vented continuously, leading to a large energy loss from the system. If a trap fails while closed, condensate can back up within the steam system, damaging equipment and reducing the performance of your steam system.

Faulty steam traps that are leaking badly must be replaced to avoid large leaks. Typically, a well-maintained steam system will experience failure in 10% of its traps within a one-year period⁵. To avoid large energy losses, a steam trap management programme should be put in place that:

- trains personnel
- inspects every steam trap at least annually
- assesses its operating condition
- maintains a database of all steam traps, both operational and faulty
- acts on the assessment findings.

Green fact: Even in a well-maintained steam system, 10% of steam traps will fail every year.

3. Investigate potential areas for condensate return

Condensate is the condensed water that has dropped out of the steam system as it loses energy through the distribution system. This water is then drained by steam traps. In the majority of cases, this condensate is returned to a receiver, where the water is pumped to the boiler feedwater system and recirculated through the steam system. The advantages of returning this water are:

- Less energy is required to heat the feedwater as the condensate is still at a relatively high temperature.
- Less water is drawn from the main supply and so you save water.
- Effort, energy and money have already been invested in treating the feedwater that is no longer lost.

Maximising the percentage of your condensate returned to your boiler will raise your energy efficiency. Unavoidable losses exist in certain steam applications, such as sparging steam into a tank and direct heating of process streams with steam. Opportunities for increasing your condensate return should be identified, including:

- running return lines to distant parts of the system
 - ensuring the size of condensate return piping is sufficient for changing plant heat loads
 - identifying and fixing leaks in the condensate return system
 - insulating the condensate return lines.
-

4. Check insulation

Maintaining your insulation in good condition is vital to an energy-efficient steam system. Without effective insulation on all piping, vessels and other equipment, you are constantly losing energy to the environment. Table 3 shows the cost of uninsulated piping. To ensure the longevity and continuing effectiveness of your insulation, make sure the insulation type is suitable for the temperature present and the environment it is subjected to.

Table 3: Heat loss from uninsulated piping⁵

Nominal pipe diameter (mm)	Heat transfer from uninsulated pipe exposed to 0.4m/s wind and 21°C ambient temperature (MJ/h/metre) process fluid temperature (°C)					
	93	204	316	427	538	649
12.7	1	3	4	7	10	14
25.4	1	3	6	9	14	20
50.8	2	5	9	14	22	32
76.2	2	6	12	19	30	44
101.6	3	8	14	24	37	55
127	3	10	18	28	44	66
152.4	4	11	20	34	51	76
203.2	5	13	25	42	66	96
254	5	16	30	50	79	119
304.8	6	18	34	58	92	139
406.4	7	21	42	71	113	172
508	9	26	50	86	139	211
609.6	10	30	59	101	164	250

5. Investigate opportunities to reintroduce flash steam

When water at saturation temperature and high pressure is collected in a steam trap, a portion of it will be converted to steam when it is released to lower pressures. This is called flash steam. In most condensate return systems, flash steam is transported to the feedwater system with the liquid condensate. Even though the flash steam is at a lower temperature and pressure than the main steam system, this flash steam can still be useful in low-pressure applications. A flash steam recovery system can be installed to make use of this steam.

A flash steam recovery vessel allows the low-pressure steam to be separated from the condensate thereby creating a low-pressure steam supply. The condensate separated from the flash steam is pumped to the boiler feedwater storage tank.

The low pressure steam supply obtained from separating out the flash steam can be used in multiple ways. If the flash recovery vessel is located near a process that can make use of low pressure steam then the value of using the flash steam can be most effectively realised. Once used, the flash steam may then condense and be drained back to the common condensate return line. Alternatively, the flash steam can be used in other processes for pre-heating, or for cooling if there is a high-temperature process that needs cooling. If the flash steam cannot be used for a process, it can still be condensed and returned to the feedwater, as significant energy has been invested in treating it. However, condensing it may require large volumes of water and a cost-benefit study should be conducted.

Figure 3: Flash steam recover vessel⁵

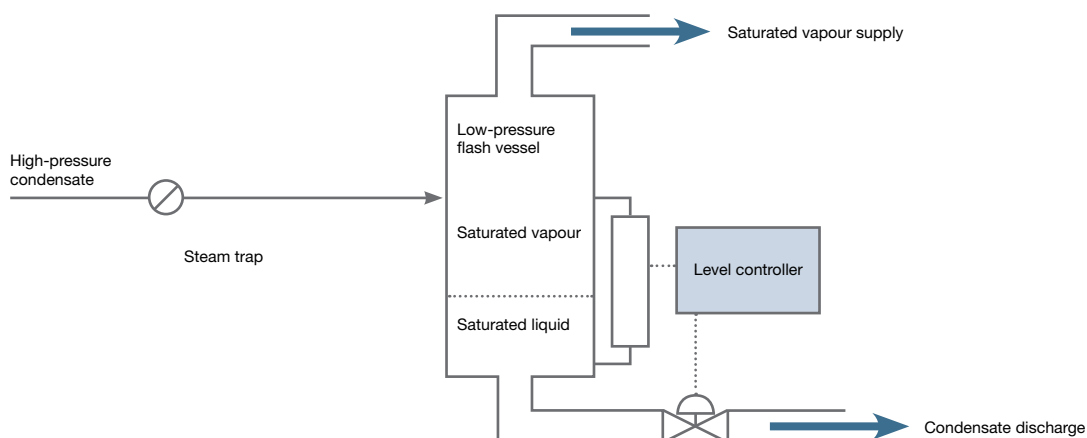

6. Investigate options for using other heat transfer media

Due to the difficulty in handling steam, it may be advantageous to transfer the heat from the steam into a more “user-friendly” heat transfer media as soon as possible. This will reduce the losses associated with running steam lines for long distances as well as ensuring the condensate is returned to the boiler with the minimum loss of temperature.

The selection of the most appropriate heat transfer fluid will depend on the temperature requirements of the end-user. Pressurised hot water systems can operate at temperatures up to 160°C at pressures up to 1MPa (10bar gauge) while specifically designed high-temperature heat transfer fluids can operate up to 400°C.

Considerations for efficient distribution of the heat transfer fluid are the same as for hot water boilers and their distribution networks. See Section 6 for more information.

7. Investigate the options for using VSDs on electric motor drives

Modern variable speed drive systems (VSDs) on electric motors have a number of advantages such as in-built power factor correction and soft start features, all of which make for longer equipment life and lower electricity charges. When used in a pump or fan system, they allow the control system to optimise the electric motor’s output to the load automatically based on measurements of pressure, temperature and/or flowrate gained from sensors around the end-users.

When considering installing VSDs on a boiler system, the best opportunities can be found in the boiler supply and exhaust air fans, and in the condensate pumps. If there are circuits with pumped heat transfer fluids these, too, will benefit from installation of VSDs on the pumps.

To make the best use of a VSD, the control system should include adequate sensors to detect the load. Eliminating throttle valves from the circuit and replacing them with appropriate sensors and VSD control systems will help realise the maximum benefit from the VSD controlled motor.

8. Consider converting to biomass or low carbon fuels

If installing a new boiler as part of an upgrade there is also the potential to convert to gaseous or liquid fuels, both of which may have biofuel options available, either in the form of tallow, biodiesel or biogas.

For solid fuels, most modern boilers are able to be fitted with fuel handling systems for biomass or coal that can be easily changed to suit the use of biomass if required.

There are a number of obvious advantages to using biomass: it is 100% renewable and relatively clean burning. Of paramount importance in a conversion is the need both to maintain the safety and integrity of the boiler and control systems, and also to improve safety to the level of best practice. For more information, refer to “Guidelines for the Conversion of Solid Fuel Boilers from Coal to Wood Pellet Firing™” published by the Bioenergy Association of New Zealand. This can be downloaded from the EECA Business website (www.eecabusiness.govt.nz). This guide draws on the collective technical experience of several industry experts: Solid Energy, Taymac Engineering, Mechserve Heating and Ventilating, Powell Fenwick Consultants, Opus International and Scion.

5.1.4 Step 4: Undertake boiler maintenance

Boiler maintenance is essential in obtaining good performance, efficiency and longevity. A regular maintenance schedule, which involves logging of boiler efficiency indicators and thorough cleaning of heat transfer surfaces is essential. Inspection of boiler insulation and refractory is also key. The maintenance instructions provided by the boiler manufacturer should be followed closely and at the recommended intervals.

Regular maintenance of boilers and their instruments, and safety valves is also essential for the safe operation of the boiler plant and steam services.

5.2 Solution 2: Design a new system

A suggested process to follow when designing a new steam system is summarised as follows:

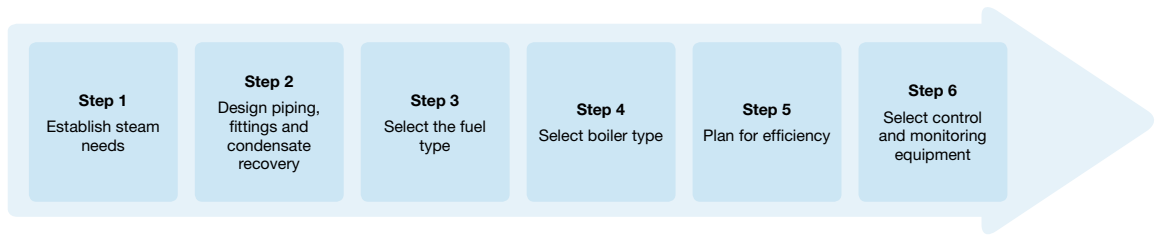

5.2.1 Step 1: Establish steam needs

When planning a new system or boiler, it is important to take stock of exactly what you use steam for and how it is used to help meet your business needs. Compile a list of all end uses of steam, the temperature, pressure and flow they require, their location and their options for heat recovery. From this list, you can establish the correct temperature and pressure and the average flow required by your system. It is important to ensure that steam and steam equipment are used safely and appropriately.

As this review is being undertaken, always ask yourself if steam is really needed for the end use. Steam is an expensive service to generate and maintain. It may be that the same level of service to an end use can be met using pumped hot water or pumped heat transfer fluid.

When thinking about the opportunities for heat recovery, consider all sources of heat around your site. Some examples are: the condensers of refrigeration systems, heat rejection heat exchangers for air compressors, furnace exhausts, gas turbine exhausts and computer room cooling equipment heat rejection heat exchangers. To assess their potential, measure and observe the temperatures available, the quantity of heat output and the match between when heat is available from the source and when you need it for your process.

5.2.2 Step 2: Design your piping, fittings and condensate recovery

Once your steam needs have been identified, you can begin to lay out your steam distribution and recovery system. This will consist of piping, fittings, valves, steam traps and possibly flash steam vessels and condensate receivers. The design of your heat recovery opportunities should also be considered at this stage. Particular thought should be given to angling of your steam pipes to allow for more convenient condensate recovery through natural drainage, rather than requiring dedicated condensate pumps.

Where possible, avoid long pipelines of small diameter. These will use a large portion of the energy contained within the steam just to overcome the flow losses and thermal losses. It may be more cost effective to install a small dedicated gas or electric steam generator close to the small end-user rather than run piping from the main boiler.

Ensure the pipe diameters are appropriate for the expected loads. If the pipe is too small, the flow losses will be too high, and there will be a risk of condensate being picked up and carried by the high velocity steam. This can result in excessive wear of the piping and components. If the pipe is too large, then the thermal losses can become high due to the larger pipe surface area.

5.2.3 Step 3: Select the fuel type

Selection of the most suitable fuel for your boiler application is an important and sometimes difficult choice. Options may include natural gas, fuel oil, biomass, coal and others. You should also include waste heat from other parts of your plant, or from an on site cogeneration system. Your decision should include considerations such as:

- boiler type required
- relative cost of fuels
- ability to store the fuel in sufficient quantities for your needs
- ease of handling the fuel
- flue gas cleaning and treatment that may be required when using particular fuels
- stability of the fuel costs
- changes to prices or your circumstances in a carbon-constrained world
- current/future government or company policies that may affect supply of the chosen fuel
- availability of a continuous supply of the fuel (for example, supply interruptions)
- the potential for fouling and the cleaning time required
- maintenance and downtime requirements
- efficiency
- net environmental impact.

Fuel types

Gas

Gas is a common and convenient fuel commonly used for small steam generators as well as some large electricity generation boilers. While natural gas is normally used, it is possible to use LPG. Air intake can be through natural convection or forced with fans built into the burner assembly.

Gas has an advantage of being quite clean burning, very controllable and having a low carbon footprint when compared to coal or fuel oil. Gas boilers are generally responsive to changing demand and can be started quickly and meet the load variations more efficiently than the equivalent solid fuel boiler.

Electricity

Electricity is less common for producing steam and tends to only be found on small steam generators. These boilers normally consist of a resistive element, which heats the water directly. Induction steam generators also exist. These work by inducing a current in a metal block within the water flow. The metal block heats up and transfers the heat to the surround water.

Electricity is usually more expensive than gas for steam generation but has the advantage that the boilers can be quite small and do not have flues, and so are able to be located close to the end-user. They are also able to meet a varying load easily and can be switched on and off without incurring the same energy and time costs as any of the boilers based around combustion technology.

Wood

Woody biomass can come in a variety of forms that boilers can use. The selection of the most appropriate form will depend on the size of the boiler, available method for storing the fuel, ease of handling, availability of biomass that may be generated on site or locally and cost.

Wood pellets

The easiest to handle and one of the most efficient forms is wood pellets. The low moisture and uniformity of the pellets means that the combustion is clean and efficient while also allowing smooth control of fuel delivery to the combustion zone.

Wood chips

Wood chips may be used as a fuel. The relative uniformity of the wood chips makes for a smooth delivery of fuel to the combustion zone, but the natural variability in moisture content means that the combustion is less efficient than for wood pellets. This also means that combustion control to maintain the correct flue gas oxygen levels is more complex.

Wood waste

Wood waste will generally be generated on site, and may be in a variety of forms from wood fibre as produced by a medium density fibreboard factory, to sawdust and hog fuel as produced by sawmills. Furniture manufacturing industries also produce wood shavings as a waste stream. Generally the fuel feed system used for boilers using waste wood fuel needs to be chosen carefully to ensure their smooth operation and minimise the boiler downtime from fuel feed blockages.

- Wood fibre and wood shavings have low moisture content and so have good combustion properties. Being more or less a uniform size, they can be fed to the combustion zone quite smoothly and easily. It is common for furniture manufacturers to compress their wood waste stream into firelogs for the domestic market.
- Hog Fuel: Hog fuel is comprised of the strips of wood, bark and dust that are left over from sawmilling and log handling operations. The moisture content can be high depending on the local weather at the time, and the ash content can be significantly higher than most biomass fuels due to the high concentration of bark and the potential that gravel has been collected during the handling operations. A robust fuel handling system is required and a boiler operator available to respond to any fuel feed system problems.
- Sawdust: Sawdust can be fed to combustors without problems due to the uniformity of the particle sizes, but it can have a high moisture level depending on the dryness of the wood when it was cut. The combustors need to be designed to handle sawdust.

Diesel

Diesel is generally only used for small heat plant due to being a relatively expensive liquid fuel option. The combustion is clean and easily controlled. The advantage for small boilers is that storage is straightforward and does not require a large area. Biodiesel can be substituted for mineral diesel for a low carbon footprint option.

Fuel oil

Fuel oil is cheaper than diesel, but does not burn quite as cleanly due to the wider range of hydrocarbon molecule sizes present and the presence of pollutants such as sulphur and sulphur compounds. The fuel oils can be quite viscous, and so combustion and fuel handling equipment needs to be specifically designed to handle it.

Fuel oil comes in a number of grades ranging from light fuel oil, which is similar to diesel, up to heavy fuel oils, which are the heavy fractions of crude oil left after the distillation process has removed everything else.

Coal

Coal comes in a variety of grades (or ranks) ranging from lignite, a low-quality, high-moisture fuel, to anthracite, which is a very hard coal with low moisture. Most New Zealand industrial boilers run on either sub-bituminous coal or lignite. Coal has a wide range of moisture content, ash content and sulphur content. The fuel feed handling properties of coal are typically quite good, but the high ash and emissions of sulphur can make it unsuitable for some applications.

A table of fuel properties can be found in Appendix D.

5.2.4 Step 4: Select boiler type

There are two types of boilers commonly used in New Zealand – water-tube boilers and fire-tube boilers. The determining factor in boiler selection is the nature of the process, particularly with regard to temperature and pressure requirements.

Water-tube boilers

Wire-tube boilers have separate steam and water drums that are connected by tubes through which the water circulates. Hot combustion gases from the furnace pass over the tubes, heating the water. The pressure vessels (drums) are relatively small and hold a comparatively small amount of water. Wire-tube boilers have a high rate of water circulation and heat transfer compared to their fire-tube equivalents. Their design is such that they are more competent in dealing with large, rapid load swings than are fire-tube boilers. They are much more demanding in their operating requirements, particularly water treatment, than are fire-tube boilers.

Wire-tube boilers are much better suited to high-output, high-pressure operation than are fire-tube boilers and operating pressures up to 140bar are not unusual. They are nevertheless quite widely used in small applications that require a high operating pressure to achieve a higher process temperature than would be achievable with a fire-tube boiler.

Fire-tube boilers

Fire-tube boilers are robust, incur a relatively low capital outlay and have less demanding operating parameters than do wire-tube boilers, particularly with regard to water treatment. With a fire-tube boiler, the entire boiler is in essence the pressure vessel and there are physical and manufacturing constraints which impose an upper limit on size and operating pressure. Fire-tube boilers are the most widely used up to the 6MW – 8MW range. There are exceptions but, for example, a 12MW fire-tube boiler would typically be over 10 metres in diameter. In fact, wire-tube boilers are physically smaller than their equivalent-sized fire-tube counterparts. The Boiler Code-of-Practice imposes an upper pressure constraint on fire-tube boilers of 17bar although there are a few exceptions to that in some specialised applications (for example, fertiliser manufacture). Fire-tube boilers, because of their comparatively large steam storage capacity, offer the advantage that they work quite well as steam accumulators.

Steam accumulators

Steam accumulators can be used to store steam for use at peak steam demand times. This allows a smaller-sized boiler to be used because it only needs to meet the average steam demand, leaving the peak demands to be met by the accumulator. By running the boiler steadily at close to its optimum load, the best running efficiency can be achieved. Using steam accumulators in the right application can save capital costs as well as running costs.

Steam usage

The steam generated by boilers can be used in two ways:

- at high pressure (> 4200kPa) to drive turbines or reciprocating engines
- at lower pressure (700kPa to 1400kPa) to supply heating services to processes through heat exchangers, or by direct injection into the process.

In some plants, a combination of these uses is employed. High-pressure superheated steam is used to drive a turbine for generating electricity, and the turbine exhaust steam is used for heat transfer applications. In these systems, the condensate is generally returned to the boiler for reuse and the overall efficiency is almost 80%.

In most industrial and commercial plants, steam is only used for process and environmental heating. It is important to optimise the efficiency of each part of such systems through proper selection, sizing, operation and maintenance.

The pressure at which you choose to distribute steam will be a balance between high pressures, which minimise pipe sizes and subsequent heat losses, and low pressures, which minimise the formation of flash steam from the discharged condensate.

In industrial processes, the decision to use either heat exchangers/jackets or direct steam injection is determined by the:

- required rate of heat transfer
- agitation of solutions
- nature of the product
- operating temperatures
- cost of feedwater treatment
- risk of contaminating the product.

Most common steam heated processes make use of heat exchangers and so have no direct contact between the steam and the product or heated service.

5.2.5 Step 5: Plan for efficiency

Integrating the boiler operation with the steam system demands is an important step towards obtaining the most energy-efficient steam system possible. Often, the operation of the boiler at higher capacity or for longer periods than are actually required by plant processes causes a large waste of energy. Scheduling plant processes to create as constant a steam demand as possible, over as short a time as possible, is ideal. This will reduce the time the boiler is operating at low capacity or the number of times that the boiler must be shutdown and fired up. The use of sophisticated monitoring and control systems will assist in implementing the most efficient system turndown when demand is low.

5.2.6 Step 6: Select boiler control and monitoring systems

The Boiler Control System (BCS) is a system that controls the entire boiler function including the energy input management system, water level management system, alarm system, pressure controls, trip devices, all instruments and circuitry.

Combustion control system

The nature of the combustion control system will depend on the type of fuel being fired. This control system regulates the fuel supply to the furnace and adjusts the air-fuel ratio under varying load conditions. Although its primary role is to regulate and monitor the furnace operation, it is integrated with the BCS and will shut off the fuel supply in response to a BCS command should the BCS detect a potentially unsafe condition or a transient operating condition.

Should the BCS detect a potentially unsafe condition, it will shut down and lock out the combustion control system and will not permit a restart until the condition has been normalised and the control has been manually reset. This type of event is called a safety trip, or lockout, and includes low-water level, loss of water supply, combustion air fan or feedwater pump failure and so on.

Should the BCS detect a transient, temporary operating excursion (for example, high steam pressure or high combustion chamber temperature), it will shut down the combustion control system but it will permit an automatic restart once the transient condition has self-corrected. This is called a cutout condition.

Oil and gas-fired boilers are equipped with sophisticated combustion control systems that include programmed startup/shut down logic, fuel supply regulation, control of the air-fuel ratio over the entire load range and flame failure detection. Should a flame failure occur on startup or during normal operation, the flame monitoring device will shut down and lock out the burner thereby preventing a potentially dangerous accumulation of combustible gases in the furnace or boiler gas passages. On burner startup, the programmed logic controller automatically initiates a sequence of events that includes a gas system integrity test (on gas-fired boilers), a furnace purge cycle and an ignition sequence. If ignition failure occurs on startup or during normal operation, the burner will shut down and lock out.

Solid fuel fired boilers are equipped with stokers of which there is a variety of types. The exact nature of the combustion control system will depend on the type of stoker used but will incorporate some means of regulating the fuel supply, combustion air supply and air-fuel ratio. Larger solid-fuel fired boilers may also be equipped with more complex combustion air distribution control features that allow regulation of the combustion air to different areas of the furnace. This provides the ability to maximise furnace efficiency when fuel quality and moisture content are variables.

Unlike oil and gas-fired boilers, solid-fuel fired boilers do not employ a programmed burner logic. There is no flame-failure detection nor does the furnace undergo a purge cycle on startup. The combustion control system does, however, operate under the command of the BCS. Should the BCS detect a potentially unsafe condition or transient operating excursion elsewhere on the boiler, it will shut down the combustion control system. That will at least include shutting off the fuel supply to the furnace and closing the inlet air damper.

IMPORTANT NOTE: *It should be noted that in large furnaces and with coal-firing in particular, the fuel in a hot furnace may continue to volatise for a long time and in this condition will generate combustible gases which may accumulate in the boiler gas passages creating a potentially explosive atmosphere. For that reason, it is not considered good practice to shut the furnace outlet (stack or flue) damper. The natural draft induced by the stack will assist in preventing this condition.*

Water level control

This system controls the water level in the boiler by monitoring the water level and controlling the supply of feedwater. On small boilers this is usually achieved by simple ON/OFF operation of the feedwater pump. Boilers larger than 3MW are required to be equipped with continuously modulating level control. High-performance boilers are usually equipped with more sophisticated systems that regulate the feedwater supply based on more than one variable. For example, 3-element control widely used on wire-tube boilers continuously monitors the water level, steam and feedwater flows. Using multiple inputs permits the level controller to some extent to anticipate load changes.

Steam pressure control

This system regulates the combustion control system and thereby the steam output to maintain a constant pressure in the steam header.

Safety valves

The safety valve(s) is a standalone item and there is no relationship whatsoever between that and the fuel system or the non-return valve on the boiler outlet.

Some boilers are equipped with a high-steam-pressure control that will shut down the burner (a transient condition). The safety valve, however, operates completely independently of that. It must be directly mounted to the pressure vessel, must be regularly tested and certified under the supervision of a certified authority, and must not be interfered with under any circumstances.

Non-return valves on the steam outlet are usually only fitted in multiple boiler installations. They are not a mandatory requirement in single boiler installations.

Monitoring systems

As part of the boiler monitoring system, important variables that should be monitored include fuel supply, steam flow and feedwater flow meters. This enables a range of data to be analysed, boiler efficiency to be assessed and trends in efficiency to be analysed.

6 Hot water systems

6.1 Solution 1: Improve the efficiency of your existing system

A suggested process to follow for improving the efficiency of your hot water system is as follows:

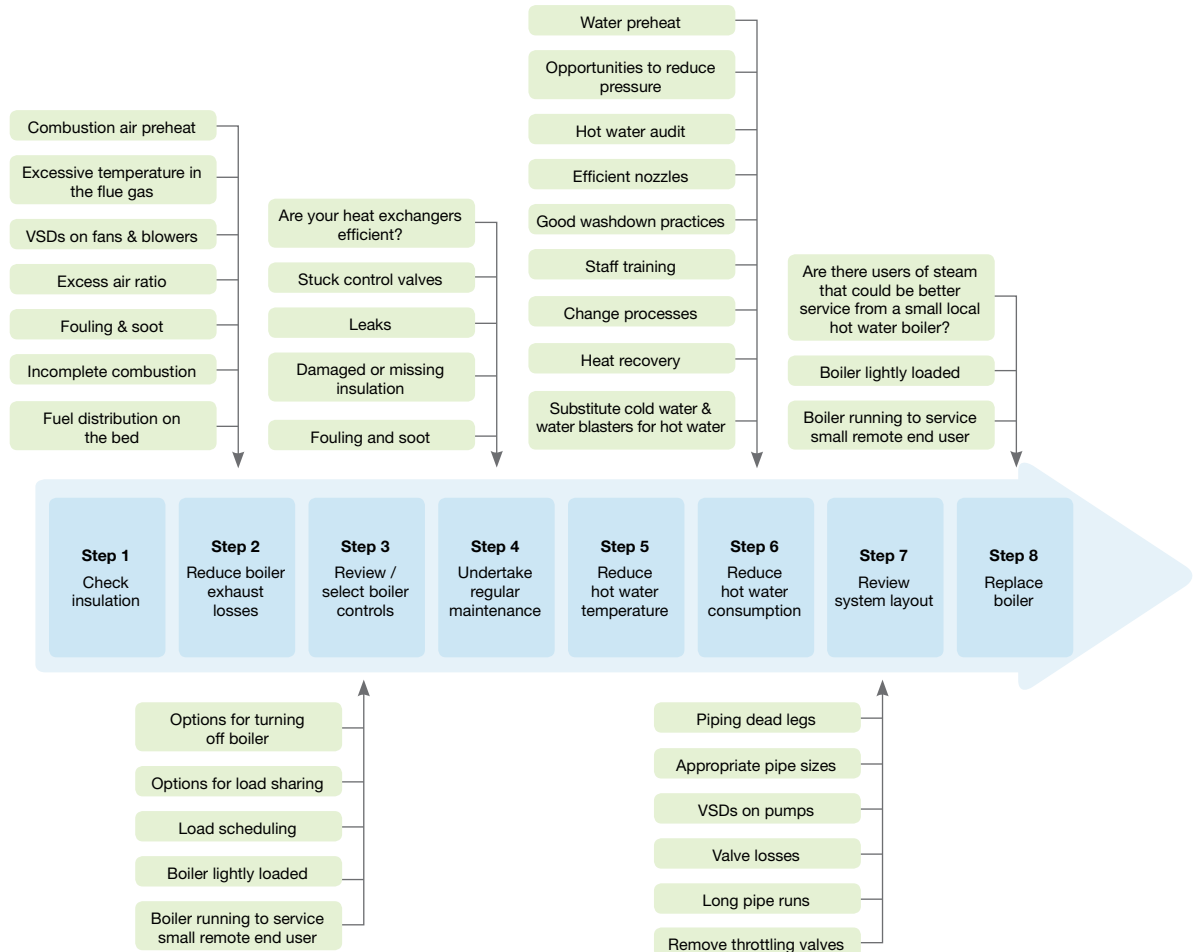

6.1.1 Step 1: Check insulation

Insulation (or “lagging”) is essential in reducing heat losses from the boiler, pipes and valves. New boilers are often very well insulated; however, older boilers may require more insulation or the insulation may have been damaged or degraded. Poor insulation can account for losses of up to 10%.⁷ Adding or replacing insulation is a simple and cost-effective measure that can improve your hot water system’s efficiency.

6.1.2 Step 2: Reduce boiler exhaust losses

The exhaust flue of a boiler is one of the major sources of heat losses. You can do things to reduce these losses. The flue draws air through the boiler, even when the boiler is not firing. This airflow cools the boiler between periods of firing. More energy will be needed in order to return the boiler to its operating temperature. A flue damper can be installed that will automatically close the flue when the boiler is not firing, thereby conserving heat; however, the appropriateness of this technology will depend on the boiler and the fuel being burned. For those boilers that cannot be closed off with dampers due to the potential for build up of combustible gases in the boiler, variable speed fans can be used to reduce the airflow through the boiler to minimise the heat loss and yet still provide enough airflow through the boiler to push out the combustible gases.

While the boiler is running, a lot of heat is lost in the exhaust gases. Recovering this heat is a good way of improving efficiency. Condensing boilers have this feature built in. The exhaust gas can be passed through a heat exchanger with either the return water (in a circulating system) or the intake air to the boiler in order to reduce the energy required by the boiler. Increasing the temperature of the intake air by 20°C will increase the efficiency of the boiler by 1%.⁷ This sort of system is called a recuperative burner system, and may need special modifications to your burner and its controls.

To get the maximum amount of energy out of the fuel, complete combustion is required. In order to achieve this, the supply of air to the combustor must be of a sufficient quantity to ensure all of the fuel will contact the air's oxygen so that it may combust fully to carbon dioxide and water vapour. The quantity cannot be too much either as the extra air will cool the boiler, and may result in high gas velocities that can lift the fuel out of the combustion zone and prevent it from burning. It is important to ensure that the air is being supplied to the right part of the combustion zone. This will ensure good mixing of the combustion gases and air in the combustion zone. See Figure 4 for a representation of the supply of air to the combustion zone of a solid fuel boiler.

In solid fuel combustion systems, the spread of the fuel on the grate plays an important role in maximising the energy released from the fuel and minimising the air that bypasses the fuel bed and does not contribute to the energy release at all. Keep your sight glasses clean and periodically observe the distribution of the fuel on the boiler grate. It may be that full burnout is occurring too early or the fuel bed is patchy. Both will allow air to bypass the combustion zone but can be fixed with adjustment of the feed and air supply rates or attention to the fuel feed mechanism. Figure 5 illustrates the effects of poorly distributed fuel in an industrial solid fuel boiler.

Figure 4: The combustion zone of a typical simple industrial solid fuel boiler

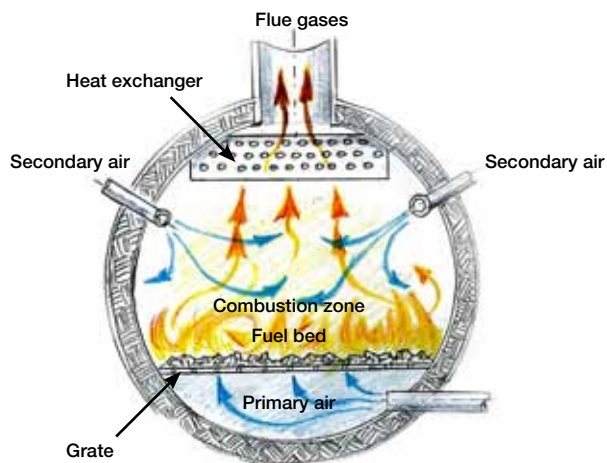
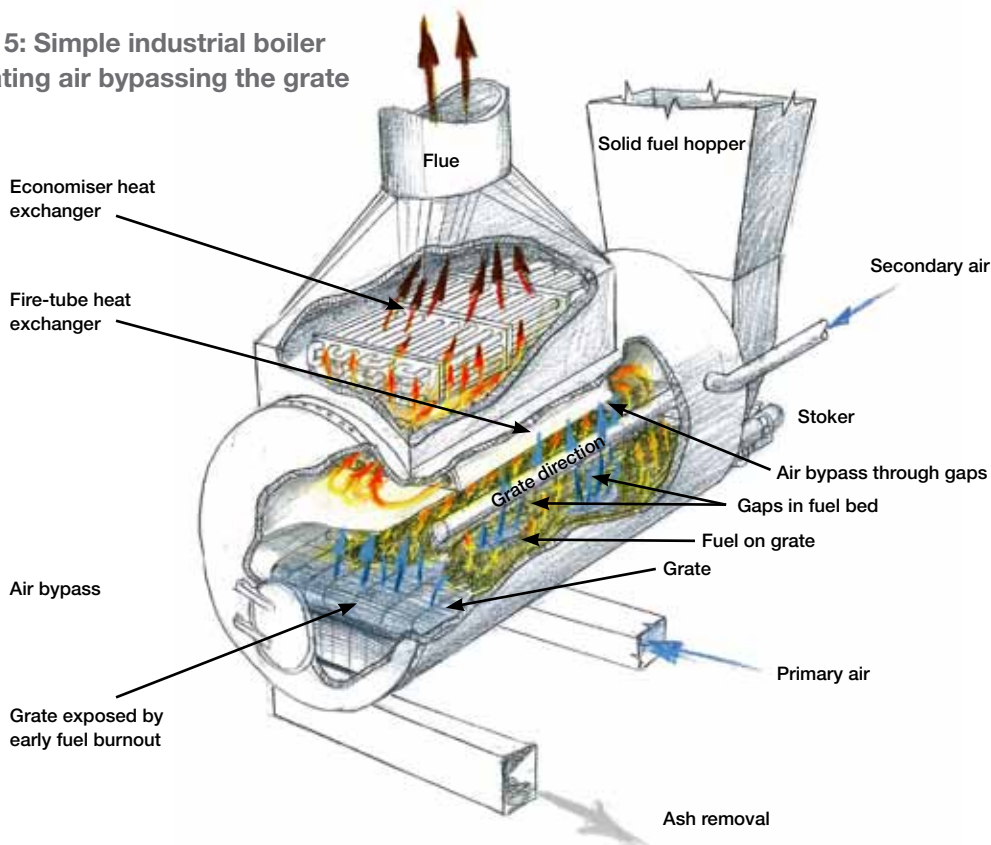

Figure 5: Simple industrial boiler illustrating air bypassing the grate



Checking that the combustion is being optimised can be achieved by measuring the level of oxygen in the flue gases. To do this, a calibrated portable flue gas analyser can be used drawing a sample from the stack (Most stacks have a sample point built into them). Where a boiler has automatic controls that measure and respond to flue gas oxygen levels, this should be calibrated regularly, and set to maintain the flue gas oxygen level at the optimum concentration. The optimum air-fuel ratio depends a little on the type of fuel being used. For solid fuel boilers, 4% to 6% oxygen concentration in the flue gases is the typical target level to achieve. Because better contact between the air and fuel can be achieved with gaseous and liquid fuels, they can be combusted closer to stoichiometric conditions which means that they will run with a flue gas oxygen concentration between 2% and 4%.

In solid fuel boilers, fly ash can collect on heat exchanger surfaces. Ash and soot have insulation properties and reduce the heat transfer to the boiler working fluid for the temperature available in the flue gases and combustion chamber. As the fouling increases, so the heat that does not usefully enter the working fluid will increase, and this will be lost up the stack. By providing good access for cleaning, and regular cleaning of the heat exchanger surfaces, the maximum amount of heat will be able to be extracted from the hot gases, with the result of less heat lost up the flue.

6.1.3 Step 3: Review/select boiler controls

The effectiveness of your boiler control system is one of the key factors in running an efficient hot water system. Check which type of control your boiler is using and whether it suits the demands of your boiler. You may wish to consult a service provider on whether your system could be adjusted to run more efficiently. A number of special control features can be employed to improve efficiency.

Burner controls

Possible types of burner control are on/off, high/low and modulating, increasing in efficiency from the former to the latter. The most appropriate type will depend on the nature of the load. Where the load is very steady, and the boiler can be run at close to its design output, there is little need for sophisticated control beyond a simple on/off control. Where the load is highly variable, a modulating control will provide the best efficiency.

The appropriateness of different control schemes will depend on the boiler technology. Some types of boilers have very poor performance when running at low load. Where there is a highly variable load and boilers with limited turn-down ability, adding a small boiler to cater for the periods of low load and using the large boiler only for periods with high loads may be a useful strategy for achieving more efficient services and operation over the range of loads expected.

Boiler interlock

By integrating the control of the boiler with thermostats on the heating distribution system, it is possible to avoid “dry-cycling”, which is the firing of the boiler while there is no demand for heat. This is quite a simple yet effective measure if your boiler experiences this problem.

Control temperature set-points

Simple boiler controls make use of temperature set points at which the boiler will automatically turn on or off. Because a boiler may need to go through a burner starting sequence that takes time and will also be likely to emit some unburned fuel before the flame ignites, it is important to minimise the number of times that the boiler restarts. By ensuring the set-points are set with a sufficiently large span between temperature at which the boiler will restart combustion and temperature at which it stops combusting, the number of restarts per hour can be reduced. This concept is illustrated in Figure 6 and Figure 7.

Figure 6: Large number of combustor starts at low load with a small temperature difference in combustion control set points

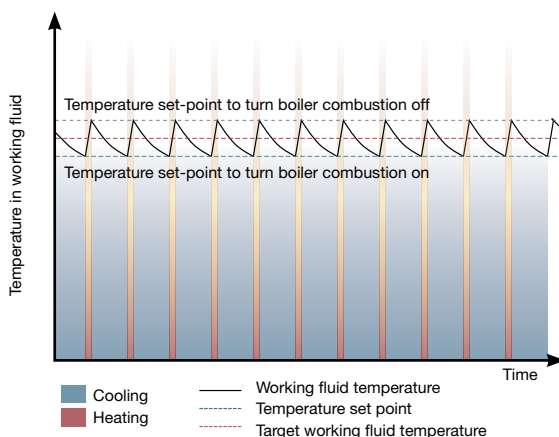
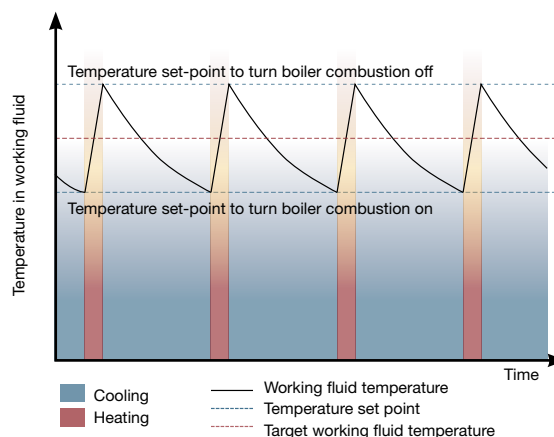

Figure 7: Small number of combustor starts with a wide temperature difference in the combustion control set points



Sequence control

If multiple boilers are used, it is possible to use sequence control to turn unnecessary boilers off and avoid running multiple boilers at part load. Efficiency is gained by operating the boilers at levels closer to their design load or not operating them at all. Where different boiler technologies are present, the operation can be set to meet the load variation with the boiler with the best part load performance and use the boiler least suited to load variation to meet any large steady base-load.

Optimised start/stop control

Often boilers have time switches to ensure the boiler is only operating during the times that production is running (for example, 8am to 6pm). An optimiser can be installed which receives input from process thermostats, allowing the boiler to operate for the shortest length of day possible while still maintaining the required heating for the process.

6.1.4 Step 4: Undertake regular maintenance

Regular maintenance of your hot water generator is essential to keep it running efficiently. A maintenance routine, maintenance manual and logbook for tracking are all important features in a maintenance plan. A number of specific maintenance tasks should be performed to ensure the best performance and lifetime for your boiler.

Analyse flue gas

Analysis of the flue gases to measure the levels of oxygen and carbon monoxide will give an indication of combustion efficiency, which can be compared against the guidelines for what should be expected for your boiler. Typically the flue gas oxygen level should be between 5% and 7% with as little carbon monoxide as possible for solid fuel combustors while gas and liquid fuelled boilers should be between 2% and 4% oxygen in the flue gas. See Section 6.1.2 for more information. Generally, gas fired combustors will operate with little or no variation in the flue gas oxygen once set. Because of variation in the fuel quality and moisture levels, the solid fuel combustors need constant monitoring of the oxygen levels in the flue gas in order to ensure they burn efficiently and cleanly.

Remove soot buildup

A badly tuned gas or oil-fired burner may result in the accumulation of soot in the gas passages. This soot is a layer of unburnt fuel particles that builds up on the fireside of the heat exchanger. Because the soot has insulating properties, it will reduce the heat transfer from the hot gases into the working fluid. A 1mm layer of soot will increase the fuel consumption of the boiler by 10% over what it would use if the surfaces were soot free in order to supply the same quantity of heat into the working fluid.⁷ In extreme cases the soot can build up to the point where it can obstruct the airflow patterns within the boiler and render parts of the heat exchanger ineffectual. The build up of soot may pose a significant fire hazard.

Remove ash buildup

All solid fuels will have some level of ash contained. This ash will either be left behind on the grate when the fuel has finished burning or be blown out of the combustion zone. The ash that is blown out of the combustion zone can settle on heat exchanger surfaces. Like soot, ash has insulation properties and will reduce the heat transfer to the boiler working fluid for the temperature available in the flue gases and combustion chamber. As the fouling increases, so the heat that does not usefully enter the working fluid will increase, and the heat that would otherwise enter the working fluid is lost up the stack. By providing good access for cleaning, and regular cleaning of the heat exchanger surfaces, the heat transfer efficiency will be maximised.

Lime-scale buildup

In areas where water hardness is a problem and the boiler make-up water is not treated, lime-scale buildup can occur on the water side of the heat exchanger. As with soot and ash buildup, this inhibits water heating. Removal of lime-scale is best done with chemical treatment. As a guide, 1mm of lime-scale on the heat exchanger heat transfer surfaces will require an additional 7% increase in heat output from the combustion in order to achieve the same heat transfer that a clean heat exchanger would need.⁷

6.1.5 Step 5: Reduce hot water temperature

The temperature set point of your boiler is a major factor in determining the heat lost throughout your system. Higher than necessary temperatures result in greater losses through increased temperatures in the flue gases downstream of the heat exchangers, and higher heat flows through insulation. By reducing the temperature of your hot water supply to the minimum required for your application, you can save significant amounts of energy.

6.1.6 Step 6: Reduce hot water consumption

A key efficiency measure is to stop hot water going down the drain. This can be done in a number of ways.

Repair leaks

Any leaks in the hot water system are causing your system to lose water and waste energy. Find and repair any leaks as far as possible. The staff on the shop floor can act as your eyes and ears in detecting any leaks, so make use of them.

Use water-efficient fittings and technologies

Use efficient nozzles and taps wherever possible as well as automatic valves where appropriate. It may involve an initial cost but will soon pay off in both water and energy savings.

Separate hot/cold outlets

Using separate hot and cold water outlets instead of a combined warm water tap may also save hot water if a manual outlet control is used, as no hot water will be used when only cold is needed.

Appropriate uses

While hot water is often easily available for use in jobs on the shop floor, a significant energy cost is involved in creating hot water, which means using hot water inappropriately is wasting energy. Ensure that hot water is not being used for jobs for which there is a more suitable alternative.

Consider higher system pressure

There is a trade-off between using higher pressure water sprays (which use more electricity, but less hot water and therefore heating energy), and low-pressure systems. Consider the application of high-pressure systems for cleaning or other uses.

Preheating and reuse in clean-in-process (CIP) systems

CIP systems can require a lot of hot water. Through the use of multiple holding tanks, water and energy-efficiency gains can be made as follows:

- Water from the first rinse: *To drain.*
- Water from the second rinse: *Store in a tank to be used in the first rinse of the next cycle.*
- Third/final rinse water: *Store in a tank to be used as the second rinse of the next cycle.*
- Fresh water: *Use as the final rinse only.*

6.1.7 Step 7: Review system layout

Industrial piped services are notorious for being designed and added to in an ad-oc manner which leads to a piping network with plenty of scope for performance improvements. Rationalising the pipe network will not only save pumping and heating losses but may also have gains in terms of easier maintenance and better control. Below is a list of actions that can improve the piping network:

- Minimising the distance between your hot water boiler and the end uses of your hot water will save you significant heat losses from piping.
- Where a single small hot water end use is separated from most of the other hot water processes by a substantial distance, consider installing a small local water heater system to supply that single end use.
- Ensure the pipe diameter is adequate for the flow. On old pipe networks that have been added to and modified over time, sections of narrow pipe diameter can often be found. These lead to greater pressure losses and hence higher pumping losses. Replace these sections with larger-diameter pipes. If the water demand has reduced over time, you may find that the pipework is larger diameter than it needs to be; in this case, the thermal losses will be higher than for a smaller pipe of the right diameter.
- Remove dead legs. In modifying pipe networks, dead-end pipelines can occur when an end-user is removed, but the supply pipelines are left in place. These are less of a problem in hot water systems than for steam systems, but they are still a place where heat can be lost through conduction down the unused pipelines.
- Install VSDs on pump and fan motors and appropriate sensors and controls to allow the motors to best match the demand in an efficient manner. VSDs have advantages for the site electricity system through good power factor performance and soft-start functions that reduce the starting peak current.
- Remove throttling valves, and unnecessary pipe bends. By removing all unnecessary flow restrictions and elements that contribute to the flow losses, the pumping losses can be reduced.
- Avoid running hot water pipework through cold or chilled spaces. This will eliminate extra load on refrigeration systems as well as the boiler.
- Look for opportunities for heat recovery from the highest temperature water processes' waste flows.
- Use hot water storage tanks to meet peak loads.
- Insulate any hot water storage tanks.

6.1.8 Step 8: Replace boiler

While the energy efficiency improvement actions described in the preceding sections will help your hot water system run more efficiently, if your boiler is quite old or is in poor condition, then it may be beneficial to replace the boiler. Typical boiler lifetimes are 15 years.⁷ While replacing the boiler may appear to be a large cost, the potential savings in energy and maintenance costs of running the new boiler, as compared to the old one, could make it worthwhile.

Replacing the boiler is not as simple as reading the specifications on the nameplate of the old boiler and ordering a new one with those specifications. A review should be undertaken that looks at your site's heating demand, with your business needs in mind. To ensure this review is thorough and accurate a boiler technician or specialist engineer should be consulted. Such a review should consider the following points:

- What is the site's heating requirements?
- What is the load profile?
- What fuel supply will be used – biomass, gas, etc?
- Where will the new boiler be located?
- What configuration could be used with the boiler or multiple boilers?
- What opportunities are there for using hot water storage to meet peak demands?
- Will it be compatible with the current site heating system?
- How will maintenance costs compare to the old boiler?
- Will the new boiler reduce air emissions such as particulates and oxides of sulphur and nitrogen? How will it help meet air quality limits for the site?
- Will the new boiler operate more efficiently or with a lower environmental footprint than the original boiler?
- Can a number of smaller boilers located close to the major end-users be used instead of a single large boiler?
- What is the opportunity to eliminate the boiler altogether and use heat recovery from other processes on site?

Condensing boilers

Condensing boilers have a second heat exchanger built into the flue that extracts additional waste heat in the flue gases by condensing the water vapour. The condensed water vapour can also be captured and used in the boiler system thereby reducing water consumption. Using a condensing boiler as the replacement can save between 10% and 20% of annual energy costs.⁷

Consider converting to a low carbon fuel

If installing a new boiler as part of an upgrade there is also the potential to convert to gaseous or liquid fuels, both of which may have biofuel options available, either in the form of tallow, biodiesel, or biogas.

For solid fuels, most modern boilers are able to be fitted with fuel handling systems for biomass or coal that can be easily changed to suit the use of biomass if required.

There are a number of obvious advantages to using biomass: it is 100% renewable and relatively clean burning. Of paramount importance in a conversion is the need both to maintain the safety and integrity of the boiler and control systems, and to improve safety to the level of best practice. For more information, refer to "Guidelines for the Conversion of Solid Fuel Boilers from Coal to Wood Pellet Firing™" published by the Bioenergy Association of New Zealand. This can be downloaded from the EECA Business website (www.eecabusiness.govt.nz). This guide draws on the collective technical experience of several industry experts: Solid Energy, Taymac Engineering, Mechserve Heating and Ventilating, Powell Fenwick Consultants, Opus International and Scion.

6.2 Solution 2: Design a new system

You may need to install a brand new system, perform a major refurbishment or conduct a major upgrade. In order to ensure that your new hot water system performs well and is energy efficient, a comprehensive review of your system requirements and the installation options is needed. Engaging a service provider to perform this role is advisable, as it will require considerable knowledge and resources. While all of the above information about hot water systems is applicable to new systems, a general outline of the review sequence is as follows:

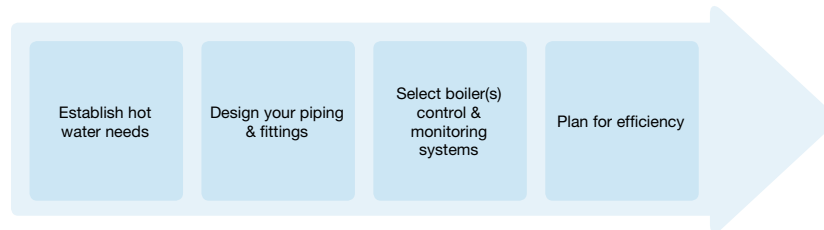

6.2.1 Establish hot water needs

As with any design process, always start with the end-user demand you are trying to meet. By understanding the end-user requirements, the quantity of heat and times that it will be needed will be able to be established.

For each point of use, ask yourself the following questions:

- What temperature and flow rate are required?
- What is the acceptable range of temperatures this process can work with?
- Is a modification to the process possible that will not require heating?
- Is there a source of heat close to the end-user that could provide most or all of the heating needs?
- What is the opportunity for scheduling end-user demand to create a more even demand across the site?
- What is the opportunity to use hot water storage to help even out hot water demand peaks?
- What opportunities exist for improving operator practices to minimise hot water service demand.
- Would a number of small hot water generators close to the end-user work better?
- What opportunities are there for fuel switching?
- Where is the end-user in relation to other end-users, and heat sources?

When investigating the opportunities for heat recovery and alternative sources of heat available on your site, ask the following questions as you evaluate their suitability:

- What temperature and heat flow are available?
- What is the working fluid that is currently carrying the heat?
- How easy will it be to capture the heat?
- Are there opportunities to improve the quality of the heat output from the heat source without compromising the quality of the primary service it is providing?
- When and where is the heat available?
- Can the heat generated be stored?

6.2.2 Design your piping and fittings

Good pipe network design involves finding a balance in pipe sizes that minimises the pumping losses while minimising the heat losses and providing the required service to the end-user location. Below is a list of pipeline design suggestions that will minimise your energy wastage:

- Ensure the pipeline distances between the heat generator and the end-user are minimised. This will reduce the flow losses and heat loss.
- Where a single end-user is located far from the rest of the hot water users and the hot water generator, consider installing a small local hot water generator rather than connecting it to the network.
- Ensure pipe diameters are designed correctly for the flows expected.
- Remove unnecessary restrictions and bends in the flow because they will all cause flow losses.
- Ensure good access to your pipe network for inspection and maintenance.
- Specify the most appropriate insulation for the temperatures and environment that the pipeline will be in contact with.
- Provide VSDs on all pumps and provide adequate sensors and control systems to maximise their effectiveness.
- Avoid running heated pipes through air conditioned or chilled spaces. This will eliminate extra load on the refrigeration systems as well as the boiler.

6.2.3 Distributed and centralised systems

The generation of hot water can be performed in one central location and distributed to all the end uses, or the hot water can be generated with a number of smaller systems located close to where the hot water is needed. Some of the factors to consider are:

- Are the end uses of the hot water located within one building, or many?
- What is the distance over which you would need to distribute the hot water, and what would the thermal losses be?
- What is the volume of hot water you need and at which location?
- What space is available to locate boilers?
- What is the load profile during the day/season for each end-user?
- Is there an opportunity to install thermal storage tanks?

6.2.4 Select boiler(s), control and monitoring systems

The more that is known about what is happening in the boiler, pipesystem and end-users, the better the system can be operated to achieve efficiency. There are a number of sensors and controls that are required for the safe operation of boilers and hot water systems. These are specified in the relevant standards.

For efficient operations, it is necessary to know about the condition of the combustion in the boiler, the temperatures and flow rates around the pipe network and the temperatures and flow rates at the end-users. In addition to these, efficient operation of the heat plant and processes needs to take into account the conditions of the product or heated space so that the heat delivered can be optimised for the ultimate end use.

The ability to record the information from the sensors will allow trends to be observed. Trends can give information to the operator about the condition of the system and forewarn the need for maintenance or the need to investigate part of the system more closely.

When fitted with adequate control valves and automatic actuators, the control system can ensure the hot water system is operating at its optimum performance at all times thereby minimising energy waste and delivering the required service.

The important features of the control system and monitoring system for a hot water plant are:

- The system has adequate inputs to be able to control the boiler and hot water system accurately to optimise its operation.
- There are adequate sensors on the system to be able to troubleshoot problems quickly and effectively.
- The system operates the boiler and hot water system to ensure product quality is not jeopardised and working space conditions are maintained.
- The system can record the data from all sensors and easily display it in whatever format is required.
- The system can respond to abnormal events in a safe manner that allows for easy and safe resolution by the service provider.

Designing control systems for industrial and commercial services requires specialist skills that may be present within your staff if you have a large industrial site or need to be contracted in.

6.2.5 Energy source selection

The energy source options for hot water boiler systems and the considerations that need to be taken into account are the same as for steam boilers. For a discussion on the range of fuels typically used, refer to Section 5.2.3.

6.2.6 Plan for efficiency

Waste heat recovery

Waste heat from other processes (such as air conditioning, heat pumps or cogeneration systems) can be used to heat water. This may be in the form of flash steam, hot process liquids, hot flue gases from combustion or air that has already passed through a process but may still have significant heat that can be transferred to water via a heat exchanger.

To assess the suitability of a potential heat source, the minimum you must consider is: the amount of heat available and the temperature at which it is available, the ease and cost effectiveness of capturing the heat and how the time that the heat is available matches the demand for heat from your hot water service.

Some common sources of waste heat are:

- air compressors
- refrigeration system condensers
- air conditioning heat rejection equipment
- hot air extracted from over hot processes such as kilns and furnaces.

Use of thermal storage

Thermal storage can be achieved by including large volume insulated tanks in a hot water circuit. These have the advantage of being able to smooth the load on a boiler and thereby allow it to operate at its optimum efficiency. The ability to use thermal storage will depend on the availability of space and the nature of the load.

Use VSDs on electrical motors

Modern VSDs on electric motors have a number of advantages such as in-built power factor correction and soft start features, all of which make for longer equipment life and lower electricity charges. The ability to vary the motor's speed to match the load will minimise the energy used by the system.

Where possible, install VSDs on all major pumps and fan motors. To make the best use of a VSD, the control system should include adequate sensors to detect the load. Eliminating throttle valves from the circuit and replacing them with appropriate sensors and VSD control systems will help realise the maximum benefit from the VSD controlled motor.

7 Process heating systems

Process heating systems come in a wide variety of forms. Systems can range from the use of direct heating of a product with a flame (as seen in asphalt processing), heating a space to high temperatures (as seen in annealing furnaces and baking ovens), to heating the press surfaces for production of medium density fibreboard.

In their simplest form process heating systems apply heat directly to a product component, as a necessary part of the process for taking it from raw ingredients to finished product.

Because process heating systems involve such a wide range of technologies and processes, this guide cannot provide in-depth recommendations for all systems. The suggestions presented here are a starting point for anyone looking at their process, and considering ways of improving the energy efficiency of their operation.

7.1 Solution 1: Improve the efficiency of your existing system

While process heating systems can be complex, relatively simple improvements can be made with minimal investment or time that yield significant energy savings and performance improvements. Note that, while most of the steps outlined here will be applicable to all process heating systems, some will apply solely to a combustion system as opposed to electricity-based heating technologies. A suggested process to follow for improving the efficiency of your process heating system is summarised as follows:

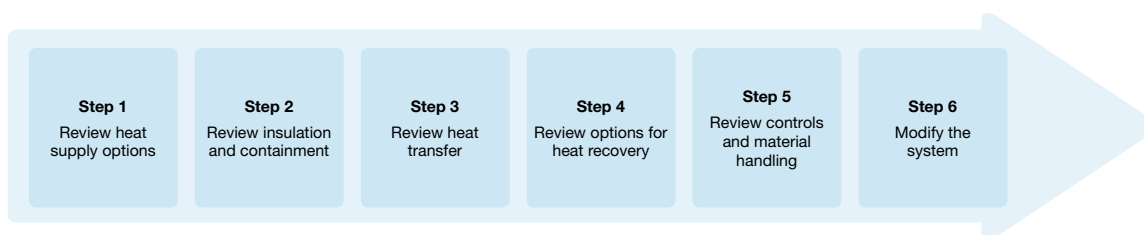

7.1.1 Step 1: Review heat supply options

Air-to-fuel ratio

Like hot water generators and boilers, any direct combustion will need its efficiency managed. See Section 6.1.3 on boiler combustion controls and maintaining efficiency over time.

Preheat combustion air

A common method of preheating the combustion air is to pass the intake air through a heat exchanger with the exhaust gases from the furnace itself. In this way, heat that would otherwise be vented to the atmosphere is transferred to the intake air. Other methods would be to preheat combustion air with return steam or cooling water from another process in a heat exchanger. Intake air preheating can save between 15% and 30% of your energy costs.²

Check condition of electrical elements

Processes heated by direct electrical resistance heating will benefit from periodic inspection of the elements. As the elements age, they can gain resistance due to deterioration of the element surface. They may also distort and move if subjected to temperature cycling. Both of these effects can lead to variations in the heat delivered and where it is delivered in the heated space. Hot spots and cold spots within the heated space may mean loss of reliable product quality as well as increased energy use if temperature sensors are not able to read the actual temperatures accurately.

Check condition of electrical inductance heating coils

Where a process makes use of inductive heating, the condition of the coils should be inspected periodically to determine that their resistance is within tolerance and that the wires are still located in their correct locations. The former condition is likely to lead to overheating of the coil and further deterioration, while the second condition may lead to a less optimal magnetic flux pattern through the space or object being heated.

Check the frequency of the supply to the inductive heating coil. Is it appropriate for the size of the object being heated and the heat penetration you require? A higher frequency will produce a shallower heating effect. If the wrong frequency is used there will be the potential for energy wastage through the need to overheat the process to achieve adequate heating in the right part of the process. The wrong frequency may also detrimentally affect the product quality by not heating to the right depth.

Check flame patterns

In gas and liquid fuel-fired direct process heating systems, observing the flame pattern can show up blocked jets and the formation of hot spots. Both of these conditions are inefficiencies that can be easily remedied with cleaning or adjustment of the jets.

Process temperature

Ensure the process temperature is set at the minimum required to maintain the desired product quality, thereby reducing heat losses from the system. Changes in your process or the materials you are using may now allow you to set a lower process temperature.

Oxygen enrichment

Where an oxygen stream is available on site, the potential exists to use oxygen enrichment of the combustion air to enhance combustion. This higher concentration leads to more efficient combustion. The saving from this technique can be between 5% and 25% of energy cost² but some of these savings will be absorbed by the energy costs of generating the oxygen.

7.1.2 Step 2: Review insulation and containment

Insulation is vitally important in maintaining energy efficiency. Containing heat loss must be a priority in order to ensure your process heating system is running well.

Insulation

At the very least, ensure that adequate insulation in good condition is installed on the following equipment:

- furnace walls
- heat transfer pipes
- intake air pipes if preheated
- heat recovery piping
- flanges and fittings.

Heat that is lost from the process is absorbed by the surrounding ambient atmosphere. If your process heating takes place within a building that is temperature controlled by a HVAC system, then poor or no insulation means that you are creating extra load for the HVAC system, and are losing money from two sources. Ensuring that your insulation is adequate can save up to 5% in energy costs.²

Air infiltration

The operation of a combustion system creates negative pressure within the furnace as the exhaust gases move out through the flue. While this ensures combustion gases do not escape to the surroundings, it may lead to the infiltration of ambient air into the furnace through leaks and openings. As this surrounding air is at a low temperature, it forces the furnace to work harder, therefore using more energy. To avoid this, the furnace should be inspected regularly and any cracks, leaks or openings due to improper seals on doors should be fixed. A pressure control system can also be installed to ensure that the furnace pressure does not encourage air infiltration. These measures can save up to 5% of energy costs.²

Hot spots

Regular inspection for localised hot and cold spots can help act as an early warning for problems with your furnace's or boiler's health. Infrared imaging can be used to assist with this task.

Minimising conductive losses

Some process heating systems will have structures connected for carrying the product to and from the heating space. Examples of this might be conveyor frames or piping. Because of heat conduction out of the heated space along the metal components, some energy efficiency gains can be achieved by insulating the fixtures immediately around the heated space or by introducing a thermal break where practical.

7.1.3 Step 3: Review heat transfer

The transfer of heat from combustion to the product is another area in which energy savings can be made.

Cleaning

Ensure that heat transfer surfaces are clean to allow for maximum transfer. Removing soot, scale, ash and other deposits from furnaces, boilers, radiant heating surfaces and heat transfer surfaces will improve efficiency.

Burners, heating elements and heat application systems

The correct and most efficient use of burners and heating elements will assist in process efficiency and product quality. Ensure that in each location within the process heating system the proper type of burner or heat application system is being used, the layout is optimised for your process and that all burners and heat application systems are in proper working condition.

Recirculation

Recirculating fans or jets can be used to ensure that the temperature throughout the heated space is consistent, increasing efficiency and improving product quality through consistent heating.

Process heating zone temperature

Zoning can be used within the process heating heated spaces to apply different temperatures to the product at different stages of the process, by varying the temperature over time, as in a batch process, or by creating different temperature zones within the furnace, as in a continuous process. The efficiency gains are through applying just the right amount of heat at the right time, rather than overheating the product for a longer time and at a higher temperature than it needs to be.

7.1.4 Step 4: Review options for heat recovery

Heat recovery is the best option for improving your process heating system efficiency. It is almost “free” energy from gases or liquids that you would otherwise dump to the environment. The higher the temperature of a waste heat stream, the higher quality it can be considered as having. This means that it has more value for use in other processes requiring heat or for heat recovery.

You may wish to consult a process heating service provider in order to gain an independent view of the best heat recovery system specific to your plant. Some of the more common heat recovery techniques are discussed below, most of which can save between 5% and 20% of your energy costs.²

Combustion air preheating

The simplest and yet one of the most effective techniques is to pass the exhaust gases through a heat exchanger to transfer heat to the intake combustion air, thereby reducing the fuel required to heat the air to the desired temperature. This technique can save between 10% and 30% of your fuel cost.²

Product preheating

Where your process allows, it may be possible to use the exhaust gases (or other sources) to preheat the product before it enters the process heating system heated space. This may be carried out by passing the product through the hot flue gases, through clean air heated by the hot flue gas or through an air to fluid heat exchanger in the case of liquid products. As with combustion air preheating, this leads to significant fuel savings.

Cascading

If you have multiple process heating applications, you may be able to cascade waste heat from one process to another. If you have exhaust gases from one process that are, for example, at 120°C, while another process is being heated to only 80°C, then you can use the waste heat of the exhaust of the first to assist in heating the second. This technique can be used to cascade waste heat through multiple different processes, either by using the exhaust of the original process in subsequently lower temperature processes, or by transferring the waste heat from each process to the next.

Hot water and steam generation

Waste heat from a process can be used to assist in the generation of hot water or even steam for your site. Using the exhaust gases of a process to preheat intake water for a hot water boiler, or preheat the condensate return of your steam generation boiler, is a very simple and yet efficient way to reduce your total energy costs.

Absorption cooling

As well as using exhaust gases for heating, it may also be possible to use them for driving an absorption cooling process. In an absorption refrigeration cycle, large amounts of heat are required to boil the refrigerant out of the absorption fluid that is used during the compression stage of the process. This makes absorption refrigeration systems ideally suited to applications where refrigeration is required and there are large sources of waste heat available. Because the absorption refrigeration system is able to make use of a pump to achieve a high compression rather than a compressor, it uses less electricity. Absorption refrigeration design is a specialist skill and expert technical advice should be sought when considering this option.

7.1.5 Step 5: Review controls and material handling

Opportunities for energy savings through heat generation, transfer, containment and recovery have been considered. There are also opportunities for savings by optimising the process control, material handling and auxiliary systems of the process heating system. These will be dependent on your system – ensure that any efficiency improvement study takes a whole-systems approach.

Process control

Starting and stopping a heating process can consume a significant amount of energy in reheating the heating system components. If using a batch process, minimising the time between batches will ensure that the heat lost during idle time and the resulting energy expended to reheat the process heating equipment are minimised. The benefit of this will depend on the thermal mass of the process heating system and practicalities of handling hot product or putting cold product into hot spaces.

Material handling

The time the product is subjected to heating will depend on what the product requires in order to complete the process step to the quality required and on the material handling system. By setting the material handling system to keep the product in the heated space for only as long as it needs, the process efficiency will be optimised as well as the heat applied to each item of product.

Turndown

Boilers and some process heating systems have a minimum heat output below which they must turn off. The turndown ratio is an expression of the boiler or process heating system's ability to operate over a range of outputs. It is a ratio of capacity at full heat output to its lowest heat output before shutdown. This is a feature of the boiler or process heater and the technology used within it. Ideally the larger the turndown ratio, the more efficiently the heating device will be able to meet a varying heat demand. Generally the only way of changing the turndown ratio is through replacement of the boiler or process heating device or retrofitting different burner or element control technologies.

Advanced materials

Many parts of a process heating system may need to be cooled to ensure proper functionality and longevity. With the advent of new materials, you may be able to replace these parts with new technology, which will provide the same function without requiring cooling, which saves energy. Also, many parts that are exposed to large amounts of heat have considerable mass in order to maintain integrity. Newer materials can be used that will withstand those temperatures while having a smaller mass, meaning that less energy is required to heat them during furnace startup.

Sensors

By having adequate sensors to monitor the process and the heating system, the better the performance and efficiency of the process can be known and acted upon. Placement of sensors will depend on the process, but typically the sensors will be temperatures, air and product flow rates, flue gas oxygen and carbon monoxide concentration (if combustion heating used) and current and voltage (for electrically heated processes). By capturing the data transmitted from the sensors into a history plot or table, trends in the process performance will be able to be observed and problems pre-empted.

Auxiliary systems

Process heating systems require many auxiliary systems, including forced draft fans, fluid pumps and material handling system motors. Effective and efficient operation of each of these systems is part and parcel of running an efficient process heating system.

7.1.6 Step 6: Modify the system

If, after the key energy efficiency measures have been implemented, your process heating system is not performing well, due to either old age or poor condition, replacing your process heating equipment may be the best option. This presents an opportunity to carry out a review of your process heating needs, rather than simply replacing the original system with the same.

Taking a holistic approach that considers your anticipated heating requirements, potential to modify the process to reduce or eliminate heating, material handling systems, heat recovery options and control systems is important in planning for the system that will give you the best performance with the lowest energy costs possible. The capital and installation cost of typical industrial heating systems is only a fraction of the operating cost over the equipment's lifetime.

7.1.7 Performance improvement tools

A number of free software-based tools are available that can be used to assist in the assessment of your process heating system and identify options for energy-efficiency improvements. These tools are:

- Process Heating Assessment and Survey Tool
- NOx Emission Assessment Tool
- The Combined Heat and Power System Application Tool for the Process Heating Industry.

For details of these tools, and where to find them, see Reference 2.

7.2 Solution 2: Design a new system

If you are planning a new process heating system you should plan for efficiency by considering the measures mentioned in this guide. A comprehensive study of your heating requirements, both at startup and in the foreseeable future, should be undertaken. A process heating service provider can assist with this study and the design of the system in order to provide the most comprehensive options and the best energy efficiency achievable.

8 Selecting a service provider

Many of the suggestions made in this guide to improve the efficiency of your hot water, steam or process heating system may require substantial time, expertise, equipment and resources. In such cases, you may prefer to contact a service provider to perform some or all of the work for you. In either case, there are some questions you should ask before you begin.

8.1 Questions to ask service providers

Will the provider take a systems approach?

It is important that your service provider considers how to optimise your entire system, not only one or two of its components. This will maximise the opportunities open to you for achieving an energy-efficient system.

Will the provider examine the demand side as well as the supply?

While the supply side of equipment is an important consideration, the provider should also be investigating the demand side of your system for opportunities to reduce or eliminate the need for heating.

Other questions:

- What analysis services do they offer (for example, boiler efficiency testing, load profile analysis)?
- What training does the provider's staff have in energy efficiency?
- Are they qualified to work on all relevant equipment and install metering?
- Do they provide emergency service response?
- Will they take care of parts shipping?
- Will they contract out any of the work themselves?
- Do they have the capability to remotely monitor your system?
- Can they provide emergency rental equipment if required?
- What training can they provide your staff and operators?
- Are they able to advise on heat recovery options and provide equipment to suit the identified opportunities?

Appendix A: Steam system overview

Steam systems are very common in industrial and manufacturing plants around the world.

Figure 8 shows a basic steam system for an industrial plant.

Figure 8: Typical basic steam circuit

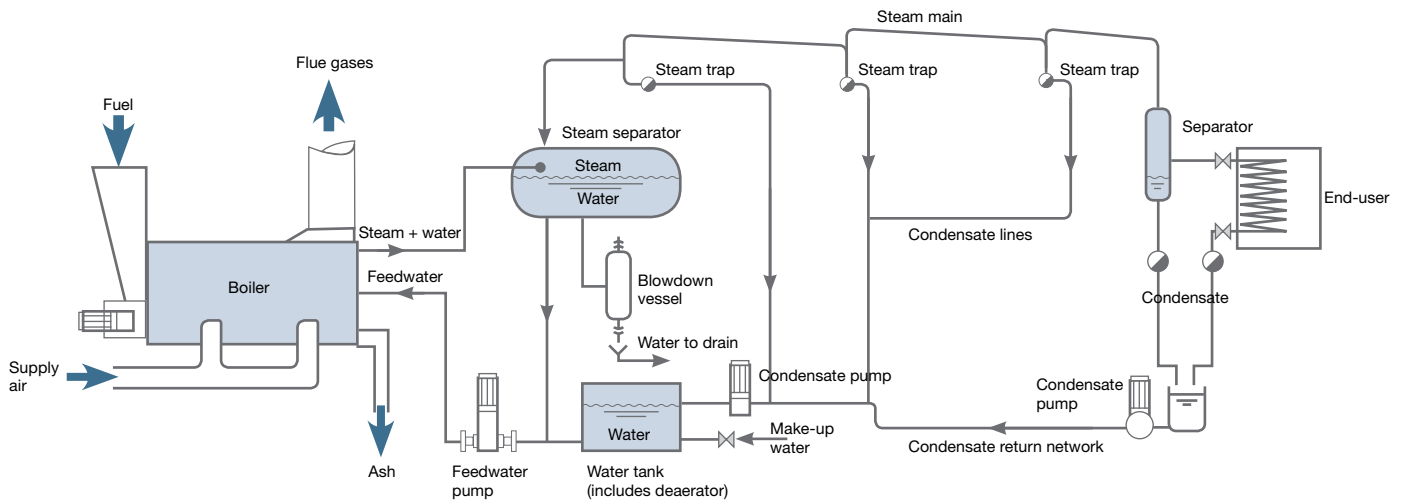

A brief description of each component follows:

Boiler: Typical steam boilers and steam generators in New Zealand are either coal fired or gas fired. In some instances steam generators are electrically powered but these tend to be small applications such as for autoclaves in hospitals or HVAC humidification. In a steam boiler using combustion to provide heat, the main components likely to be encountered are:

- Fuel handling equipment which may include spreaders, fans for air conveyed fuel, screw feeders, all of which are different types of stokers that will be designed to handle different types of solid fuel. Valves and regulators will be present on gas fired systems, while pumps and control valves will be present on liquid fuel fired systems.
- Purpose designed burners and nozzles will be present on liquid and gaseous fuel systems. These will be designed to ensure the optimum mixing of fuel and air and produce the most suitable flame pattern for the type of boiler.
- Supply air handling system. This will consist of ducts and dampers to direct air to the right part of the firebox to ensure good combustion conditions are achieved. In some systems a fan will be used on the inlet air while others will use a fan on the flue side to draw the air through the firebox.
- A firebox of some form will be present in all combustion-based boiler systems. The shape will depend on the fuel, and whether the boiler is a fire-tube or water-tube type.
- Solid fuel boilers will also include a grate. The grate holds the fuel and in most cases will be the mechanism that will move the fuel through the combustion zone and deposit it into the ash handling system when the fuel has been burned out. There are a few cases of fluidised bed combustors in New Zealand.
- Ash removal systems will be present in solid fuel fired boilers. These are typically a conveyor system that carries the ash out of the firebox to a dumping point, or in small boilers, a hand raking operation carried out periodically by the operator.
- Heat exchangers allow good contact between the heat available in the combustion gases and the water thereby maximising the heat transfer and steam production. The type of heat exchanger used will depend on whether the boiler is a fire-tube or water-tube type, and will depend on the fuel used, particularly the nature of the ash in the fuel.

- All combustion heated boilers will include a flue. The flue may include fans that induce a gas flow through the entire boiler system. Depending on the fuel being burned, emission control equipment may also be present. These can be bag houses, electrostatic precipitators and cyclones for particulate emission control or wet scrubbers for control of gaseous emissions such as oxides of sulphur.
- Control systems for boilers range from very simple to sophisticated computer control that is able to monitor and control the oxygen content in the flue gas, fuel feed rates, temperatures and pressures, and provide a historic record of the boiler performance.
- In New Zealand there are a few instances where fluidised bed combustors are used. These are a solid fuel combustion system where air is blown through a bed of sand containing particles of fuel. The mixture behaves like a bubbling fluid. The advantage of this type of system is that they are able to reliably handle fuels with varying moisture content more easily than most other types of solid fuel boiler.
- An economiser may be fitted to the boiler flue system to capture the waste heat and use it to preheat the boiler feedwater before it enters the boiler.

Steam separating equipment: The water heated in a steam boiler will exit the boiler as a two phase mixture of steam and liquid water. The mixture is separated in a vessel with a volume that will allow the liquid water to settle out. The liquid water can then be returned to the boiler for further heating while the steam enters the steam distribution system. In some cases the steam will be superheated by passing it back through the boiler using a heat exchanger dedicated to superheating.

Blowdown system: Over time, the water inside the boiler will accumulate sludge, suspended solids and dissolved solids naturally occurring in the feedwater itself. If not removed, these can accelerate corrosion and decrease the performance of the boiler and steam system. Periodic blowdown where steam is vented into a vessel open to the atmosphere will remove a portion of the contaminated water from the system so that it may be replaced with fresh water. Blowdown may be a manual operation or automatic triggered by a timer or in the more efficient systems by water quality monitoring equipment detecting concentrations of contaminants reaching a maximum allowable level.

De-aerator: The purpose of a de-aerator is to remove air from the steam system. Oxygen and carbon dioxide can contribute to accelerated corrosion of the steam distribution network and components. Because air is a non-condensing gas it can interfere with the efficient operation of heat exchangers by preventing the steam from reaching parts of the heat exchanger where it would otherwise be able to condense.

Steam distribution network: This will consist of a pipe network to carry the steam from the boiler and steam separator to the end-user. The pipes are sized to minimise the pressure losses, heat losses and also keep the steam velocities low enough that it will not pick up condensate. All pipes in a network have a gradient to ensure condensate can be efficiently drained from the pipe system. Steam traps are distributed throughout the pipe network to collect and release the condensate that forms on the pipe walls. Control valves, pressure relief valves and sensors will also be present on the steam network to control and monitor the flows to the various end-users.

Steam traps: The primary role of a steam trap is to maximise latent heat recovery from the steam while at the same time preventing condensate accumulation in the steam system. They discharge condensate, whilst not allowing live steam to escape. Due to the wide variety of applications under which steam traps are required to operate, they come in many shapes and sizes to suit those applications, including:

- thermostatic (operated by changes in fluid temperature)
- thermodynamic (operated by changes in fluid dynamics)
- mechanical (operated by changes in fluid density).

Separators: Separators can be present throughout a steam network where high-quality steam delivered to an end-user is important. The wet steam enters a separator and slows down due to the diameter of the separator vessel being larger than the steam pipe. The condensed water can drop out of the steam and be transferred to the condensate return network while the now dry steam can be passed through the process. Separators may also be fitted with equipment to remove air.

End-user: The end-user will tend to be a heat exchanger, but some processes may use direct injection of steam to heat a process, or be used for providing mechanical equipment such as turbines. Where the steam is not used directly in the process, the condensed steam can be collected and returned to the boiler for reuse.

Condensate return network: The condensate return network is a pipe network that gathers up the condensate from processes and steam traps and carries it back to the feedwater tank. Pumps and small collection tanks are likely to be found on a condensate network.

Feedwater tank: Condensate and make-up water are collected in the feedwater tank. Automatic dosing of corrosion inhibitor chemicals may also occur in the feedwater tank.

Feedwater pump: Water from the feedwater tank is pumped to the boiler to start the process again. Flow from the boiler feed pump is usually controlled by a modulating valve that is connected to a water-level sensor in the boiler. As the water level drops due to steam production, more water is supplied with the boiler feed pump.

Steam accumulator: In some installations a steam accumulator may be present. This is a method of storing steam for use during high-demand periods. Steam from the boiler is injected into the accumulator, which contains water under pressure at its saturation temperature. When the demand for steam exceeds the boiler's capability, the discharge valve opens and flash steam is created, as the discharge pressure is below that of the accumulator. In this way, the accumulator provides for the excess demand that the boiler cannot handle, allowing for a smaller boiler to be used but still providing for peak capacity. Also, when demand is low, the boiler will charge the accumulator with steam, providing extra demand on the boiler and so flattening its load profile. In the case of fire-tube boilers, the volume of water contained within the boiler itself can achieve the same function as having an accumulator.

Figure 9: Steam accumulator (side and end views)⁸

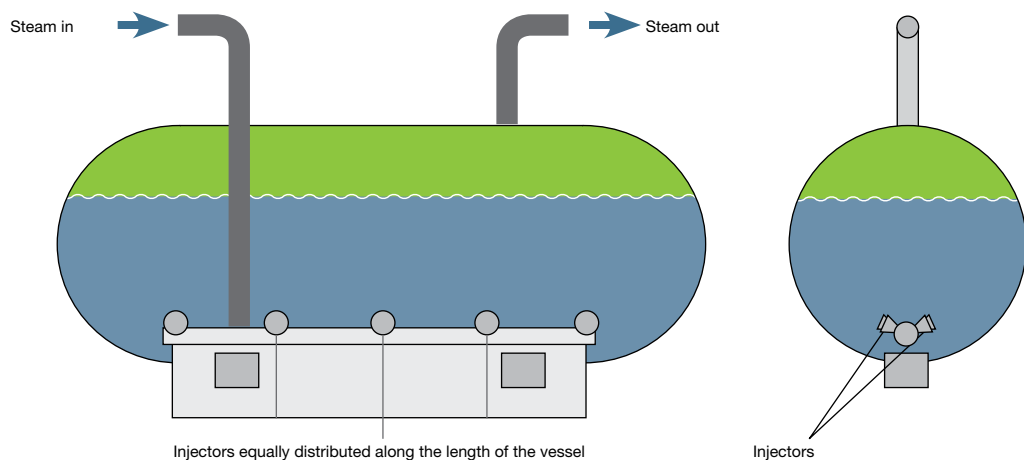

Common boiler configurations

There are two boiler designs in wide use within New Zealand. They are fire-tube and water-tube boilers.

Fire-tube boilers: Figure 10 illustrates the typical flow path for the combustion gases and the likely temperatures in a typical fire-tube boiler installation. In these boilers, the combustion gases from the burner flow through the inside of the tubes, with the water that will be evaporated to steam on the outside of the tubes. Figure 11 shows a cut away view of a typical fire-tube boiler.

Figure 10: Typical flow path through fire-tube shell boiler⁸

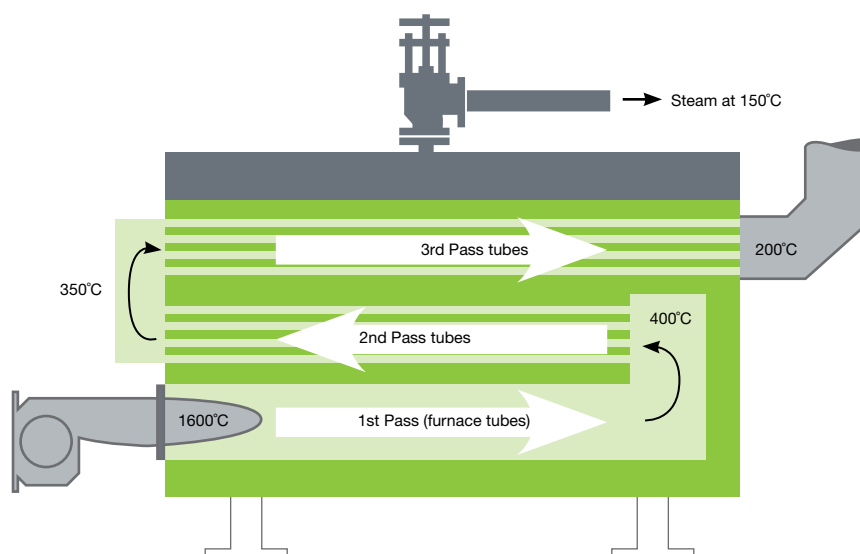
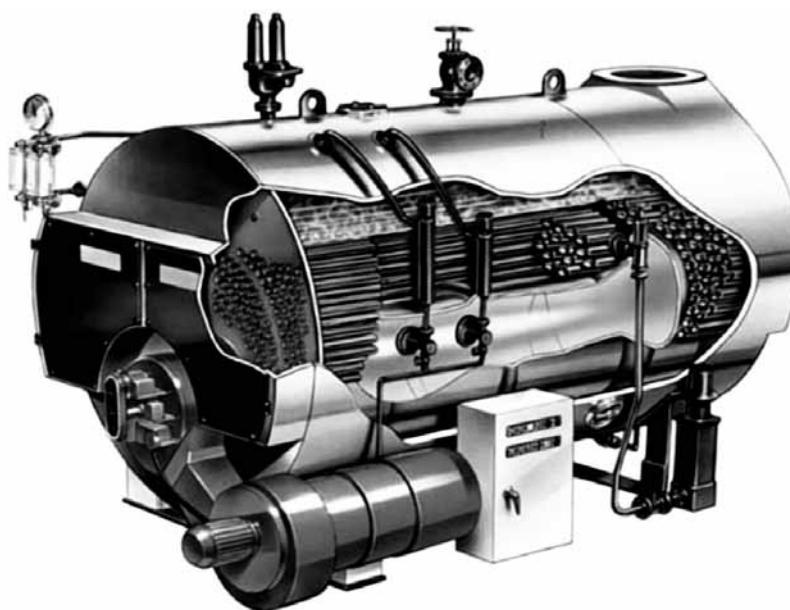
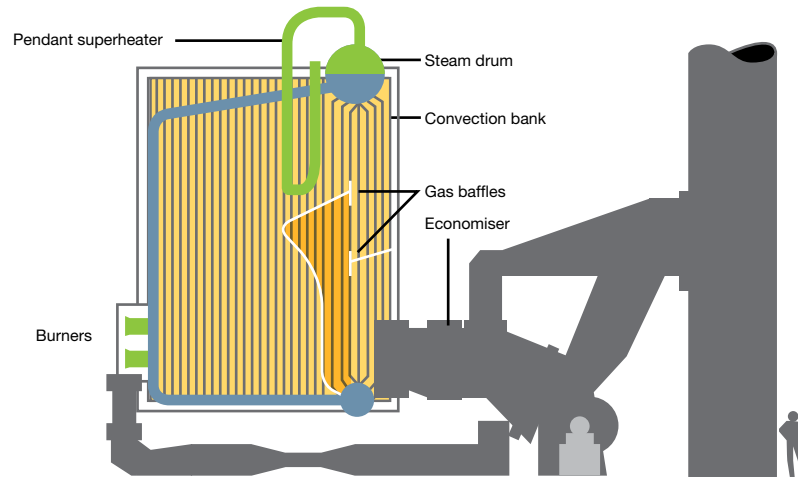

Figure 11: Modern package boiler⁸



Water tube boilers: Water tube boilers are often used in larger applications such as power generation and large process industries. This is because the smaller diameter of the steam and water drums allows higher steam pressures to be generated, such as those required for power generation using steam turbines.

Figure 12: Water-tube boiler⁸



Appendix B: Hot water system overview

Hot water boilers are very common services in both industrial and commercial operations. Where other working fluids such as hot oils are used, the system is same.

Figure 13: Basic components in a commercial hot water boiler system

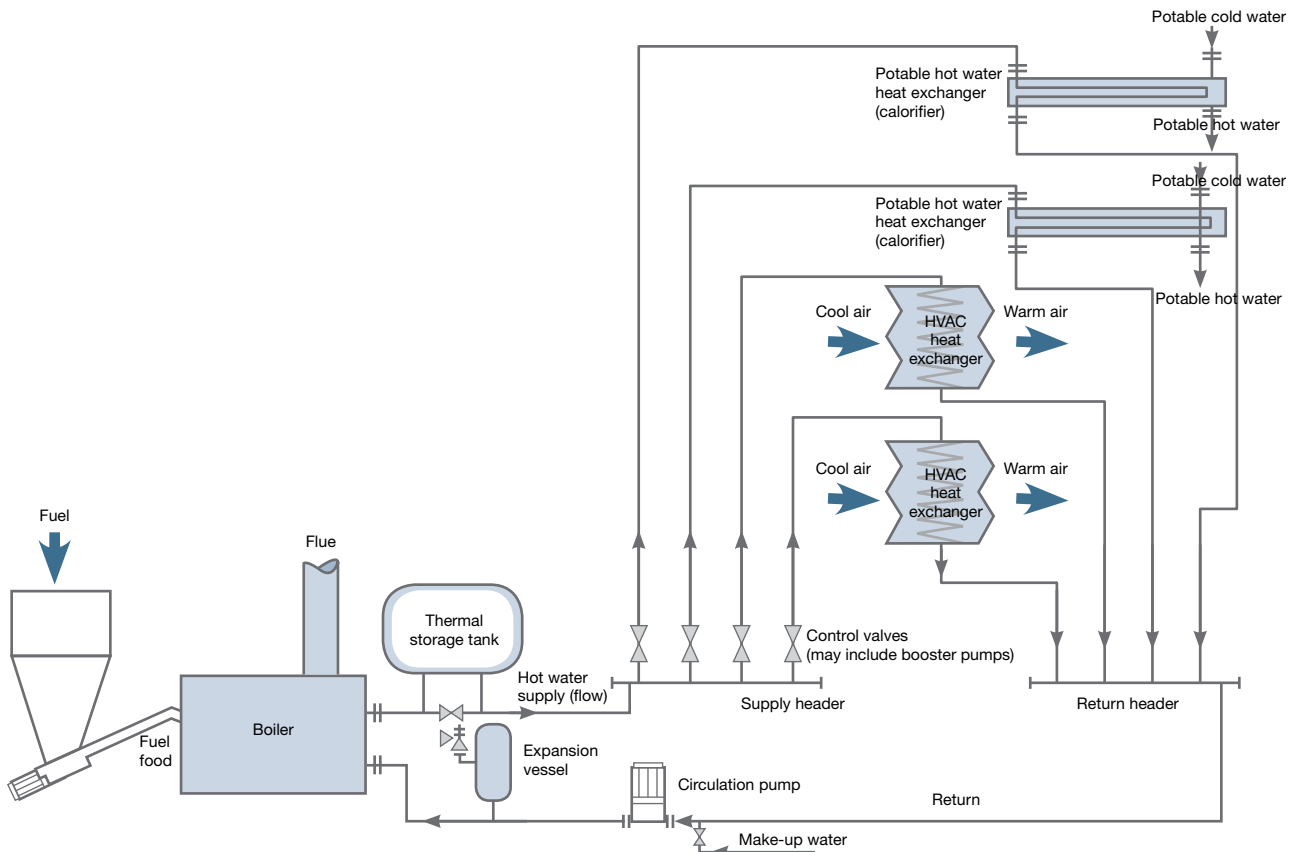

Boiler: Typical hot water boilers in New Zealand are gas fired, diesel fired, fuel oil fired. An increasing number are now fired on wood pellets. Hot water boiler systems usually include the following components:

- Fuel handling equipment which may include spreaders, fans for air conveyed fuel, screw feeders, all of which are different types of stokers that will be designed to handle different types of solid fuel. Valves and regulators will be present on gas fired systems, while pumps and control valves will be present on liquid fuel fired systems.
- Purpose designed burners and nozzles will be present on liquid and gaseous fuel systems. These will be designed to ensure the optimum mixing of fuel and air and produce the most suitable flame pattern for the type of boiler.
- Supply air handling system. For gaseous and liquid fuels, the air will tend to enter the combustion chamber through the burner system together with the fuel. In solid fuel boiler systems the air supply will consist of ducts and dampers to direct air to the right part of the firebox to ensure good combustion conditions are achieved. In some systems a fan will be used on the inlet air while others will use a fan on the flue side to draw the air through the firebox.
- A firebox of some form will be present in all combustion-based boiler systems. The shape will depend on the fuel, and whether the boiler is a fire-tube or water-tube type (see the description of fire tube and water tube boilers in Appendix A).
- Solid fuel boilers will also include a grate. The grate holds the fuel and in most cases will be the mechanism that will move the fuel through the combustion zone and deposit it into the ash handling system when the fuel has been burned out.

- Ash removal systems will be present in solid fuel fired boilers. These are typically a conveyor system that carries the ash out of the firebox to a dumping point, or in small boilers, a hand raking operation carried out periodically by the operator.
- Heat exchangers allow good contact between the heat available in the combustion gases and the working fluid (in this case water) thereby maximising the heat transfer. The type of heat exchanger used will depend on whether the boiler is a fire-tube or water-tube type, and will depend on the fuel used, particularly the nature of the ash in the fuel.
- All combustion heated boilers will include a flue. The flue may include fans that induce a gas flow through the entire boiler system. Depending on the fuel being burned, emission control equipment may also be present. These can be bag houses, electrostatic precipitators and cyclones for particulate emission control or wet scrubbers for control of gaseous emissions such as oxides of sulphur.
- Control systems for boilers range from very simple to sophisticated computer control that is able to monitor and control the oxygen content in the flue gas, fuel feed rates, temperatures and pressures and provide a historic record of the boiler performance.

Expansion vessel: The water circuits in hot water boiler systems are normally operated at pressures in the range 6 to 10bar so as to achieve water temperatures in the 140°C to 160°C range. This means that the circuit needs to be fully closed. In order to accommodate the expansion of the water as it heats up and yet still be able to maintain the pressure, an expansion vessel is included in the circuit.

Hot water circuit: This will consist of a pipe network to carry the hot water from the boiler to the end-user. The pipes are sized to minimise pressure losses and heat losses. Control valves and sensors will also be present on the hot water circuit to control and monitor the flows to the various end-users. In some circuits, booster pumps may also be present. The pipes carrying the hot water from the boiler to the end-users are called the “flow” or “supply”, while the pipes carrying the water back to the boiler are called the “return”.

End-user: The end-user will tend to be a heat exchanger. In the most common hot water boiler systems, the hot water will be used in HVAC air heating coils, or calorifiers for heating potable hot water.

Circulation pumps: The circulation pumps of which there are usually two in parallel, drive the water around the circuit.

Thermal storage tank: Also known as an accumulator, a thermal storage tank is a large volume insulated tank that holds heated water. This can smooth the load on the boiler and also take advantage of off-peak energy charges.

Appendix C: Process heating system overview

Process heating systems generally transfer energy from an energy source to a product. The enormous range of industry-specific processes and technologies makes it impossible to consider all variants in this guide. A typical process heating system can be characterised as follows (Figure 14).

Figure 14: Key components of a process heating system²

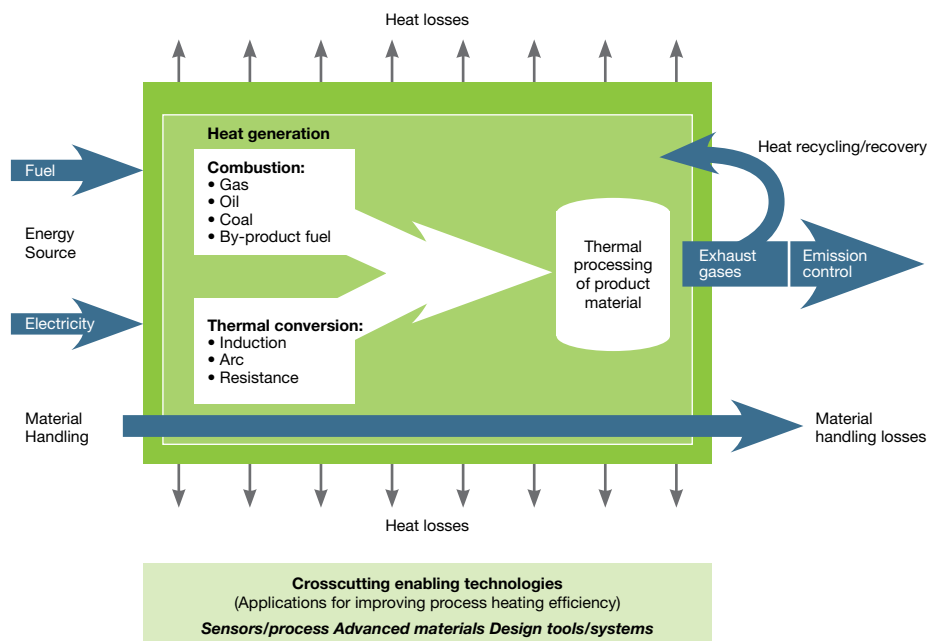

Key components in a process heating system are:

- fuel or electricity supply – gas line, electricity distribution board
- heat generation equipment – boiler, furnace, dryer, resistance
- heat transfer method – convection, radiation, fluid heat transfer
- material handling system – fluid, conveyor, roller, rotary heater
- heat recovery system – heat exchange between exhaust gases and intake combustion air
- exhaust emissions – furnace flue.

Process heating systems can be classified in a number of ways, as shown in Table 4. Two such classifications are the *mode of operation* and the *heating method*. The mode of operation distinguishes how the material is moved through the process:

- **Batch:** A set amount of material is processed at a time, before moving on to allow the next batch, in a start/stop fashion.
- **Continuous:** The material moves through the process at a constant rate.

The heating method is usually one of the following:

- **Direct:** Heat from combustion is applied directly to the material, therefore the combustion gases are in contact with the material and open burners or heating elements are used.
- **Indirect:** The material is separated from combustion. Heat is transferred using gases or liquids and heat exchange takes place with the material. Indirect heating equipment includes radiant burner tubes and covered electrical heating elements.

There is also a large range of energy sources and material handling systems used.

Table 4: Process heating classification²

Furnace classification method	Equipment/application comments	Primary industries
Batch and continuous		
Batch	Furnaces used in almost all industries for a variety of heating and cooling processes	Steel, aluminium, chemical, food
Continuous	Furnaces used in almost all industries for a variety of heating and cooling processes	Most manufacturing sectors
Type of heating method		
Direct fired	Direct-fired furnaces using gas, liquid or solid fuels or electrically heated furnaces	Most manufacturing sectors
Indirect fired	Heat treating furnaces, chemical reactors, distillation columns, salt bath furnaces	Metals, chemical
Type of energy used		
Fuel fired	Process heaters, aluminium and glass melting furnaces, reheat furnaces, ovens	Most manufacturing sectors
Electrically heated	Infrared ovens, induction melting and heating furnaces, electric arc melting furnaces	Metals, chemical
Steam heated	Dryers, fluid heating systems, water or slurry heaters, tracing	Pulp and paper, chemical, petroleum refining, food
Other	Air heaters, polymerising heaters, frying ovens, digesters, evaporators	Chemical, food
Material handling system		
Fluid heating (flow through) systems	Gaseous and liquid heating systems including fluid heaters, boilers	Petroleum refining, chemical, food, mining
Conveyor, belts, buckets, rollers	Continuous furnaces used for metal heating, heat treating, drying, curing	Metals, chemical, pulp and paper, mining
Rotary kilns or heaters	Rotary kilns used in cement, lime, heat treating, chemical and food industry	Mining, metals, chemical
Vertical shaft furnaces	Blast furnaces, cupolas, vertical shaft calciners, and coal gasifiers	Metals, petroleum refining
Rotary hearth furnaces	Furnaces used for metal or ceramics heating or heat treating of steel and other metals, iron ore palletising	Metals
Walking beam furnaces	Primarily used for large loads such as reheating of steel slabs, billets, ingots	Metals (steel)
Car bottom furnaces	Used for heating, heat treating of material in metals, ceramics and other industries	Metals, chemical, ceramics
Continuous strip furnaces	Continuous furnaces used for metal heating, heat treating, drying, curing	Pulp and paper, metals, chemical
Vertical handling systems	Primarily for metal heating and heat treating for long parts and in pit, vertical-batch and salt-bath furnaces	Metals, chemical, mining
Other	Pick and place furnaces	Most manufacturing sectors

Efficient energy sources

A number of different energy sources can supply your process heating application. These include:

- heat recovery
- biomass
- natural gas
- electricity
- steam
- liquefied petroleum gas
- diesel
- fuel oil
- coal
- cogeneration.

Heat recovery is the use of exhaust or return fluids from a process to heat a process or assist in making combustion more efficient. It should always be considered first as a supplement to your primary energy source. Examples of heat recovery are:

- Using furnace exhaust gases to heat intake combustion air via a heat exchanger.
- Using engine cooling water to heat a process.
- Using return low-pressure steam to heat a process.

While in some cases the ease of access to gas or electricity might make it tempting to perform heat generation solely with these fuels, the savings associated with using heat recovery are likely to significantly offset any extra time and investment required to implement a heat recovery option.

Cogeneration is the generation of electricity and production of useful heat at the same time. A fuel is combusted on site to drive an engine. In large installations the fuel can be coal or biomass used to raise steam for a steam turbine, while smaller installations may use diesel or biodiesel in a diesel generator set. The electricity generated by the engine and generator set can be used on site or sold if more electricity is generated than used by the site. The waste heat from the engine can then be used to produce hot water. The viability of cogeneration will depend on the relative prices of fuels and electricity for a particular site and on the need for hot water.

Your choice of the energy source for your process is a very important one and is worth reassessing at regular intervals. While your current energy source may have been suited to your business needs at the time of installation, a change in your process needs may mean that a different energy source may now be more appropriate, and more effective. Also, changes in the market price of different energy fuels may mean that it is now cost effective to switch fuel source. In order to make an informed decision on the best choice of energy source for your process heating application you may wish to contact a process heating service provider.

Appendix D: Fuel properties

The following table summarises the typical properties of various types of fuel.

Solid fuels (as received basis)

Fuel	Moisture (%)	Ash (%)	Volatiles (%)	Fixed carbon (%)	Higher calorific Value (MJ/kg)	Bulk density (kg/m ³)	Cost (\$/GJ)	Notes
Wood pellets	2.4 – 8.0	0.3 – 0.4			18.5 – 19.5	620	13 – 22	No carbon cost. Minimal particulate emissions.
Sawdust	55	0.15 – 0.6	37.0	7.5	9.0	250 – 400	Free*	No carbon cost. Possible particulate emissions, likely volatile organic compounds.
MDF fibre	4 – 5	0.2 – 0.3			19.0 – 19.5		Free*	No carbon cost. Minimal particulate emissions.
Waste paper	9	3 – 60	1.6 – 2.5		8.5 – 15			No carbon cost. Likely high levels of fly ash.
Hog fuel	5 – 70	1 – 14	24 – 40	6.9 – 10	6.5 – 18.5	160	Free*	No carbon cost. Possible particulate emissions, likely volatile organic compounds.
Wood chips	50 – 70	0.13 – 0.25	35 – 50	6.5 – 10	7 – 12	150 – 550	3 – 12	No carbon cost. Minimal particulate emissions, possible volatile organic compounds.
Coal - lignite ¹³	29 – 41	3.2 – 6.3	29 – 38	26 – 27	15 – 18.5	500 – 900	3.3 – 8.7 ¹¹	Very high carbon cost, emissions of particulates and oxides of sulphur may be a problem.
Coal - sub-bituminous ¹³	20 – 30	3.4 – 6.2	32 – 34	33 – 41	19 – 23	600 – 950	4.5 – 8.2 ¹¹	Very high carbon cost, emissions of particulates and oxides of sulphur may be a problem.

* if generated on site

Liquid fuels

Fuel	Higher Calorific Value	Cost (\$/GJ)	Notes
Diesel	38.3MJ/L 43.6MJ/kg	24 ¹⁰	High carbon cost (unless biodiesel used), minimal air quality issues.
Fuel oil	40.8MJ/L 43.6MJ/kg	21 ¹⁰	High carbon cost, particulates, sulphur emissions and volatile organic compounds a potential problem.

Gaseous fuels

Fuel	Higher Calorific Value	Cost (\$/GJ)	Notes
Natural gas	39.3 – 41.3MJ/m ³	9 – 16 ¹⁰	Medium carbon cost (unless biogas used), no air quality issues.

Electricity

Cost	Notes
\$33 – \$43/GJ ¹⁰	Medium carbon cost, no local pollutants

Appendix E: Glossary

Term	Meaning
absorption cooling	A form of refrigeration system to produce process cooling (cold air or chilled water) that uses heat as the predominant input energy source, as opposed to an electric chiller that uses electricity to drive a compressor.
blowdown system	System for removing sludge and suspended solids that build up internally in a boiler system. Improves efficiency and increases life of boiler.
boiler	Device that produces steam or hot water for use in a process.
boiler interlock	Mechanism for preventing dry-cycling in a boiler.
capacity utilisation	A ratio of the average output/throughput of a boiler (or other piece of process equipment) compared to the rated capacity/throughput.
cascading	A method of using waste heat from the first process to be used in a subsequent process and so on.
coefficient of performance (COP)	A measure of the efficiency of a refrigeration system defined as cooling duty (kW) / input power (kW).
condensate	In the context of an enclosed industrial steam system, it is steam that has been converted from a vapour to a liquid and, in the process, has given up the majority of its heat.
condensate return	System for recapturing condensate and transferring it back to a boiler. This allows the sensible heat remaining within the condensate to be reused.
de-aerator	System for removing oxygen, carbon dioxide and other gases that could potentially increase corrosion in a boiler system.
dry-cycling	Unnecessary firing cycles in the boiler when heating is not required in the process.
economiser	System to capture waste heat from boiler exhaust to preheat feed water or some other process.
flash steam	Saturated steam generated as a result of hot condensate going from a high pressure to a low pressure.
flue	Exhaust for a boiler using combustion as the heat generation process.
heat pump	A device based on the vapour compression cycle used by refrigeration plant, except that rather than transferring heat from a chilled space to the ambient air, it takes heat from the ambient air and transfers it to a space to be heated.
heat recovery	Capturing waste heat to be used in another processes (such as domestic hot water, preheating of boiler make-up water).
hot water pump	Circulates hot water around the plant for use in processes.
latent heat	The heat required in order to change the phase of a material (for example, liquid to vapour).
preheating	The act of heating a product before intake to the primary heating system.
sensible heat	The heat required in order to raise the temperature of a material without it changing phase.
separator	Separators are used to remove condensate as well as air from a boiler system to help prevent corrosion.
sequence control	Ability to control multiple boilers such that only the required number of boilers are switched on.
steam accumulator	A method of storing steam for use in high-demand periods, which can help stabilise the boiler operation.

Term	Meaning
steam piping	Pipe meeting national and international standards of material and wall thickness for carrying steam.
steam trap	System for allowing condensate to be removed from a steam system distribution network while preventing live steam from escaping.
turndown ratio	The ratio of a boiler's full heat output to the lowest heat output it can operate at before it must shutdown.
VSD	Variable Speed Drive. An electronic control system for controlling the speed of an electric motor.

Appendix F: Further reading

Further reading

More information about developing a business case for investing in your plant's energy efficiency, as well as detailed technical information about hot water, steam and process heating systems can be found in the following resources available freely on the Internet.

Steam

Energy Efficient Operation of Boilers, Good Practice Guide GPG369, Carbon Trust, UK, March 2004

www.carbontrust.co.uk/publications

Fundamentals of Steam System Design: A Self-Directed Learning Course, American Society of Heating, Refrigerating and Air-conditioning Engineers, US

www.ashrae.org/education/page/761

Improving Steam System Performance – A Sourcebook for Industry, US Department of Energy – Office of Energy Efficiency and Renewable Energy, US, October 2004

www.eere.energy.gov/industry/bestpractices/pdfs/steamsourcebook.pdf

Is Oxygen Trim Worth the Price?, Blesi-Evans, US, November 2007

www.blesi-evans.com/techarticles.htm

Steam System Survey Guide, Harrell G., Oak Ridge National Laboratory, US, May 2002

www.eere.energy.gov/industry/bestpractices/pdfs/steam_survey_guide.pdf

Hot water

Low Temperature Hot Water Boilers, Technology Overview CTV008, Carbon Trust, UK, March 2006

www.carbontrust.co.uk/publications

Steam and High Temperature Hot Water Boilers, Technology Overview CTV018, Carbon Trust, UK

www.carbontrust.co.uk/publications

Process heating

Improving Process Heating System Performance – A Sourcebook for Industry, US Department of Energy – Office of Energy Efficiency and Renewable Energy, US, September 2004

www.eere.energy.gov/industry/bestpractices/pdfs/proc_heat_sourcebook.pdf

Process Plant Insulation and Fuel Efficiency, Fuel Efficiency Booklet FEB019, Carbon Trust, UK, 1993

www.carbontrust.co.uk/publications

Case studies

There are many examples of businesses that have recognised inefficiency in their business processes and made an investment in becoming more energy efficient, with huge benefits for their bottom lines. Some of these businesses have taken part in EECA Business programmes. Detailed case studies of businesses, along with information about the EECA Business Programmes can be found at the EECA website www.eeca.govt.nz or www.eecabusiness.govt.nz

References

- ¹ Improving Steam System Performance:
A Sourcebook for Industry, US Department of Energy, p 3 & 30, October 2004
- ² Improving Process Heating System Performance:
A Sourcebook for Industry, US Department of Energy, p 3, September 2004
- ³ Low Temperature Hot Water Boilers, Technology Overview,
Carbon Trust, UK, p 2, March 2006
- ⁴ Energy Efficient Operation of Boilers, Carbon Trust, UK, p 4-6, March 2004
- ⁵ Steam System Survey Guide, Harrell G., Oak Ridge National Laboratory,
p 2-19, US, May 2002
- ⁶ Sustainability Victoria
- ⁷ Low Temperature Hot Water Boilers, Technology Overview, Carbon Trust, UK,
p 2-18, March 2006
- ⁸ Spirax Sarco International website, November 2007
www.spiraxsarco.com
- ⁹ BIB Cochran International website, November 2007
www.bibcochran.com
- ¹⁰ “Energy Data File – 2010”, Ministry of Economic Development
- ¹¹ “Coal Prices in New Zealand Markets”, Covec, 2009
- ¹² “Thermal Energy Equipment: Boilers & Thermic Fluid Heaters” –
Energy Efficiency Guide for Industry in Asia,
www.retscreen.net/fichier.php/882/Boilers_and_ThermicFluidHeaters.pdf
- ¹³ “Analysis Update 2010”, CRL Energy Ltd
- ¹⁴ EECA End-Use Database

Disclaimer

Information in this document is current as of October 2010. While all professional care has been taken in preparing this document, EECA accepts no liability for loss or damages incurred as a result of reliance placed upon its content.

Acknowledgements

EECA would like to acknowledge Sustainability Victoria for the original work from which this document was developed, and Geoff Pearson and Allan Estcourt for their review and suggested modifications which have helped shape this guide.

For further information:

For specialist advice on heating, go to the Institute of Refrigeration, Heating and Air Conditioning Engineers – www.irhace.org.nz

Sources of general information for business can be accessed via the Biz service website (www.nzte.govt.nz/biz) and www.business.govt.nz. Business advice for Maori can be found at www.tpk.govt.nz/en/services/business

About this guide:

This guide was adapted from a publication originally produced by Sustainability Victoria. It was peer-reviewed by EMANZ, BANZ and IRHACE representatives, Geoff Pearson (IQ Technology) and Allan Estcourt. EECA Business thanks Sustainability Victoria and the other contributors for their input.

 For more information contact
The Energy Efficiency and
Conservation Authority:

EECA HEAD OFFICE:

PO Box 388, Wellington, (04) 470 2200

EECA AUCKLAND:

PO Box 37444, Parnell, Auckland, (09) 377 5328

EECA CHRISTCHURCH:

PO Box 13983, Christchurch, (03) 353 9280

www.eecabusiness.govt.nz

DECEMBER 2010/EEC1652